

Features

1. Sustainable short-circuit protection
2. Wide working temperature range: -40 °C to +85 °C
3. Up to 88% efficiency
4. The no-load current is as low as 5mA
5. Ripple as low as 20mVp-p
6. Single output
7. Package: SMD
8. Isolation voltage: 1500VDC



3 years
Warranty

Selection Guide

| Product model | Input Voltage Standard value(range) | Output Voltage (V) | Output Current (mA) (Max./Min.) | Efficiency % (Min./Typ.) | Maximum capacitive load (µF) |
|----------------|-------------------------------------|--------------------|---------------------------------|--------------------------|------------------------------|
| AMB0503XT-2WR3 | 5VDC (4.5-5.5) | 3.3 | 400/40 | 74/79 | 2400 |
| AMB0505XT-2WR3 | | 5 | 400/40 | 79/85 | 2400 |
| AMB0509XT-2WR3 | | 9 | 222/22 | 79/85 | 1000 |
| AMB0512XT-2WR3 | | 12 | 167/17 | 79/85 | 560 |
| AMB0515XT-2WR3 | | 15 | 133/13 | 81/86 | 560 |
| AMB0524XT-2WR3 | | 24 | 83/8 | 81/86 | 220 |
| AMB1205XT-2WR3 | 12 (10.8-13.2) | 5 | 400/40 | 79/83 | 2400 |
| AMB1209XT-2WR3 | | 9 | 222/22 | 79/83 | 1000 |
| AMB1212XT-2WR3 | | 12 | 167/17 | 80/84 | 560 |
| AMB1215XT-2WR3 | | 15 | 133/13 | 80/84 | 560 |
| AMB1224XT-2WR3 | | 24 | 83/8 | 81/85 | 220 |
| AMB1505XT-2WR3 | 15 (13.5-16.5) | 5 | 400/40 | 79/83 | 2400 |
| AMB1515XT-2WR3 | | 15 | 133/13 | 80/84 | 560 |
| AMB2405XT-2WR3 | 24 (21.6-26.4) | 5 | 400/40 | 77/83 | 2400 |
| AMB2409XT-2WR3 | | 9 | 222/22 | 77/83 | 1000 |
| AMB2412XT-2WR3 | | 12 | 167/17 | 78/84 | 560 |
| AMB2415XT-2WR3 | | 15 | 133/13 | 78/84 | 560 |
| AMB2424XT-2WR3 | | 24 | 83/8 | 79/85 | 220 |

Input Characteristics

| Parameter | Conditions | Min. | Typ. | Max. | Units |
|---|-----------------------|------|------|------|-------|
| Input current (Rated Load) | Nominal voltage input | -- | 477 | 500 | mA |
| Input current (No-load) | | 4 | 8 | 20 | mA |
| Reflected ripple current | | -- | 15 | -- | mA |
| Input impulse voltage | 05VDC input | -0.7 | -- | 9 | VDC |
| | 12VDC input | -0.7 | -- | 18 | |
| | 15VDC input | -0.7 | -- | 21 | |
| | 24VDC input | -0.7 | -- | 30 | |
| Input filter | Capacitive filtering | | | | |
| Remarks : This product does not support hot plug | | | | | |

Output Characteristic

| Parameter | Conditions | Min. | Typ. | Max. | Units | |
|-------------------------------|--------------------------------|-------------------------------|---------|--------|-------|---|
| Output voltage accuracy | | See Figure 1 (envelope curve) | | | | |
| Linear regulation rate | Input voltage variation +/- 1% | -- | -- | +/-1.1 | -- | |
| Load regulation rate | 10% to 100% load | 5VDC input | -- | 7 | 15 | % |
| | | 9VDC input | -- | 6 | 10 | |
| | | 12VDC input | -- | 5 | 10 | |
| | | 15VDC input | -- | 4 | 10 | |
| | | 24VDC input | -- | 3 | 10 | |
| Ripple & Noise | 20MHz bandwidth | -- | 50 | 150 | mVp-p | |
| Temperature drift coefficient | 100% load | -- | +/-0.03 | -- | %/°C | |
| Short circuit protection | Sustainable, Self-healing | | | | | |

General Characteristics

| Parameter | Conditions | Min. | Typ. | Max. | Units |
|---|--|------|------|------|--------|
| Isolation voltage | Input output, Test time 1 minute, Leakage current less than 1 mA | 1500 | -- | -- | VDC |
| Insulation resistance | Input output, Insulation voltage 500VDC | 1000 | -- | -- | MΩ |
| Isolation capacitance | Input output, 100KHz/0.1V | -- | 20 | -- | pF |
| Working temperature | Temperature ≥ 85 °C for derating (See Figure 2) | -40 | -- | +105 | °C |
| Storage temperature | | -55 | -- | +125 | °C |
| Storage humidity | Non condensing | -- | -- | 95 | %RH |
| Housing temperature rise during operation | Ta=25 °C, Nominal input, Full output | -- | 25 | -- | °C |
| Soldering temperature resistance of pins | The distance from the welding spot to the shell is 1.5mm, 10 seconds | -- | -- | 300 | °C |
| Switching frequency | Full load, Nominal input voltage | -- | 260 | -- | kHz |
| Mean time between failures | MIL-HDBK-217F@25°C | 3500 | -- | -- | kHours |

Physical Characteristics

| Parameter | Content |
|--------------------|--|
| Housing material | Black flame retardant and heat-resistant plastic (UL94V-0) |
| Overall dimensions | 13.20 x 11.40 x 7.25 (mm) |
| Weight | 1.4g(Typ.) |
| Cooling mode | Natural air cooling |

EMC Characteristics

| Parameter | Category | Content |
|-----------|-------------------------|--|
| EMI | Conductive disturbance | CISPR32/EN55032 CLASS B (The recommended circuit is shown in Figure 2) |
| | Radiation disturbance | CISPR32/EN55032 CLASS B (The recommended circuit is shown in Figure 2) |
| EMS | Electrostatic discharge | IEC/EN61000-4-2 Contact ± 6 KV perf. Criteria B |

Circuit Design and Application



Figure 1: Application circuit

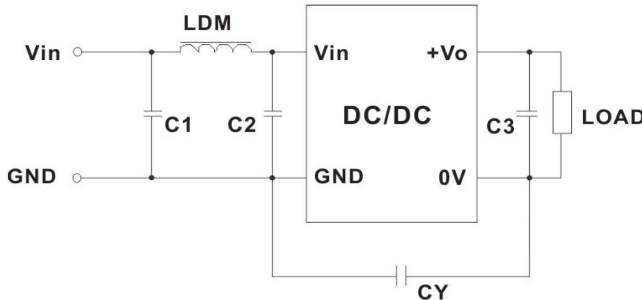

Figure 2: EMC Typical Recommended Circuits

Table 1: Recommended Capacitive Load Values

| Vin(VDC) | Cin(μ F) | Vo(VDC) | Cout(μ F) |
|-----------------|---------------|-----------------|----------------|
| Nominal voltage | 10 | Nominal voltage | 1-10 |

Table 2: Recommended Circuit Parameter Values

| Category | Component | Value |
|----------|-----------|------------------------------------|
| EMI | C1 | 4.7 μ F /50V |
| | C2 | 4.7 μ F /50V |
| | C3 | Refer to Cout parameter in Table 2 |
| | CY | 270pF/2kV |
| | LDM | 6.8 μ H |

1) Typical application: If it is required to further reduce the input and output ripple, a capacitor filter network can be connected at the input and output terminals. The application circuit is shown in Figure 1. However, proper filter capacitor shall be selected. If the capacitance is too large, it may cause startup problems. For each output, under the condition of ensuring safe and reliable operation, the recommended capacitive load values are shown in Table 1.

2) Typical EMC recommended circuits are shown in Figure 2.

Product Characteristic Curve

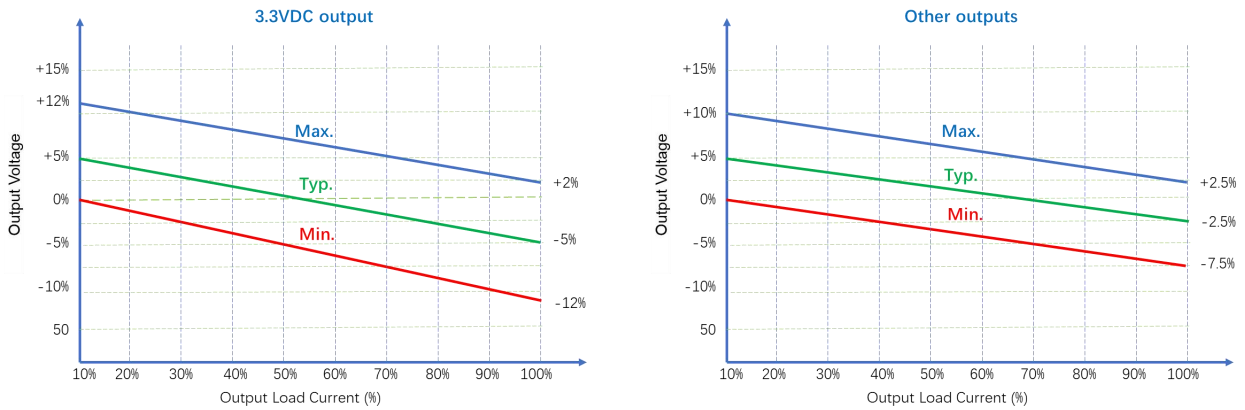

Figure 3: Voltage tolerance envelope

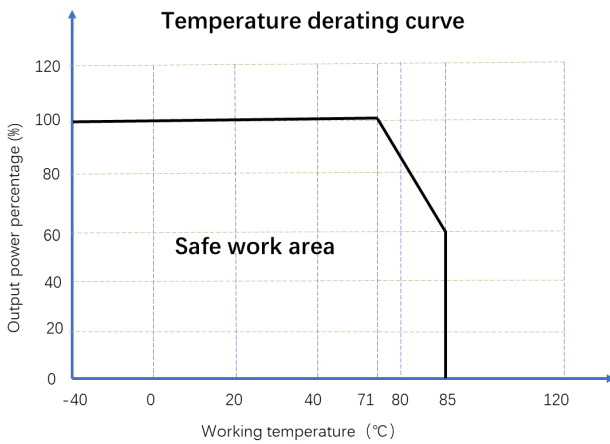

Figure 4: Temperature Derating Curve

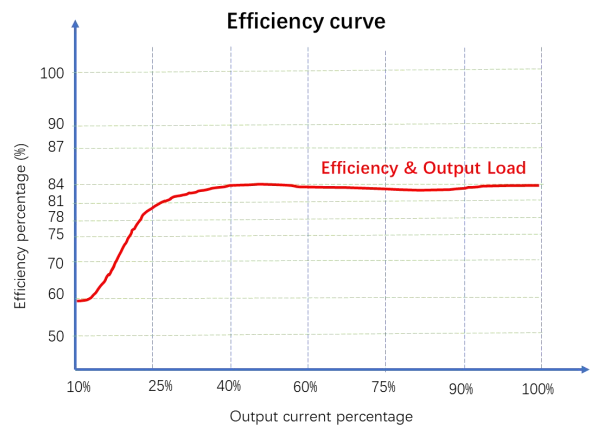

Figure 5: Efficiency VS Output Load (Nominal Voltage Input)

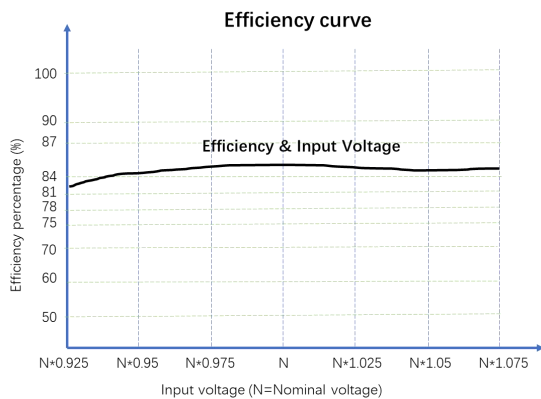
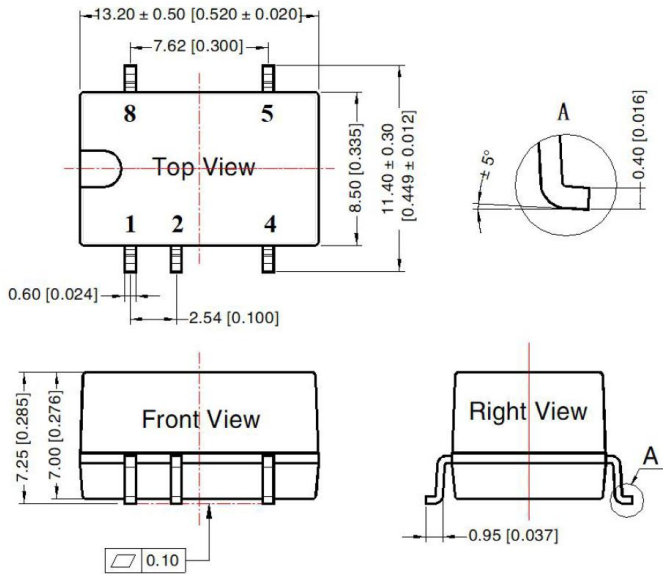

Figure 6: Efficiency VS Input Voltage (100% Load)

Overall Dimensions and Pin Functions



Note:

Dimensions in mm [inch]

Terminal diameter tolerance: ± 0.10 [± 0.004]

Undeclared tolerance: ± 0.50 [± 0.020]

Table 3: Pin Function Table

| Pin | Function |
|-----|----------|
| 1 | GND |
| 2 | Vin |
| 4 | 0V |
| 5 | +Vo |
| 8 | NC |

Figure 7: Overall dimensions

Notes & Instructions

1. If the product works under the minimum required load, it cannot guarantee that the performance of the product complies with all the performance indicators in this manual;
2. The maximum capacitive load is tested under the input voltage range and full load condition;
3. Unless otherwise stated, all indexes in this manual are measured at $T_a=25^\circ\text{C}$, humidity $<75\%RH$, nominal input voltage and rated output load;
4. All index testing methods in this manual are based on the enterprise standards of the company;
5. Our company can provide product customization, specific needs can directly contact our technical staff;