

### Features

1. Wide operating temperature range: -40°C to +105°C
2. Up to 85% efficiency
3. No load current as low as 5mA
4. Ripple as low as 30mVp-p
5. Sustainable short-circuit
6. Isolation:1500VDC
7. DC input, Output 1W, Isolated, Non stabilized voltage, Single Output, SMD package.



3 years  
Warranty

### Model Numbering

## AMBxxxxXT-1WR3

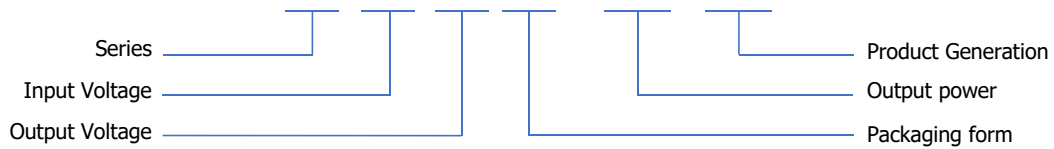

### Selection Guide

Product model	Input Voltage Standard value(range)	Output Voltage	Output Current (mA) (Max./Min.)	Efficiency % (Min./Typ.)	Maximum capacitive load (µF)
AMB0303XT-1WR3	3.3VDC (2.97-3.63)	3.3	303mA	75%	1200
AMB0305XT-1WR3		5	200mA	84%	1200
AMB0309XT-1WR3		9	111mA	84%	470
AMB0312XT-1WR3		12	83mA	84%	220
AMB0315XT-1WR3		15	67mA	84%	220
AMB0324XT-1WR3		24	42mA	85%	100

Product model	Input Voltage Standard value(range)	Output Voltage	Output Current (mA) (Max./Min.)	Efficiency % (Min./Typ.)	Maximum capacitive load ( $\mu$ F)
AMB0503XT-1WR3	5VDC (4.5-5.5)	3.3	303mA	75%	1200
AMB0505XT-1WR3		5	200mA	84%	1200
AMB0509XT-1WR3		9	111mA	84%	470
AMB0512XT-1WR3		12	83mA	84%	220
AMB0515XT-1WR3		15	67mA	84%	220
AMB0524XT-1WR3		24	42mA	85%	100
AMB0903XT-1WR3	9VDC (8.1-9.9)	3.3	303mA	75%	1200
AMB0905XT-1WR3		5	200mA	84%	1200
AMB0909XT-1WR3		9	111mA	84%	470
AMB0912XT-1WR3		12	83mA	84%	220
AMB0915XT-1WR3		15	67mA	84%	220
AMB0924XT-1WR3		24	42mA	85%	100
AMB1203XT-1WR3	12VDC (10.8-13.2)	3.3	303mA	75%	1200
AMB1205XT-1WR3		5	200mA	84%	1200
AMB1209XT-1WR3		9	111mA	84%	470
AMB1212XT-1WR3		12	83mA	84%	220
AMB1215XT-1WR3		15	67mA	84%	220
AMB1224XT-1WR3		24	42mA	85%	100
AMB1503XT-1WR3	15VDC (13.5-16.5)	3.3	303mA	75%	1200
AMB1505XT-1WR3		5	200mA	84%	1200
AMB1509XT-1WR3		9	111mA	84%	470
AMB1512XT-1WR3		12	83mA	84%	220
AMB1515XT-1WR3		15	67mA	84%	220
AMB1524XT-1WR3		24	42mA	85%	100
AMB2403XT-1WR3	24VDC (21.6-26.4)	3.3	303mA	75%	1200
AMB2405XT-1WR3		5	200mA	84%	1200
AMB2409XT-1WR3		9	111mA	84%	470
AMB2412XT-1WR3		12	83mA	84%	220
AMB2415XT-1WR3		15	67mA	84%	220
AMB2424XT-1WR3		24	42mA	85%	100

## Input Characteristics

Parameter	Conditions		Min.	Typ.	Max.	Units
Input current (Rated Load)	Nominal voltage input@3.3VDC	3.3VDC Output	--	384	405	mA
		5VDC/7.2VDC Output	--	370	389	mA
		9VDC/12VDC Output	--	365	389	mA
		15VDC/24VDC Output	--	350	389	mA
	Nominal voltage input@5VDC	3.3VDC Output	--	271	286	mA
		5VDC/7.2VDC Output	--	244	257	mA
		9VDC/12VDC Output	--	241	254	mA
		15VDC/24VDC Output	--	241	254	mA
	Nominal voltage input@12VDC	3.3VDC Output	--	112	118	mA
		5VDC/7.2VDC Output	--	105	110	mA
		9VDC/12VDC Output	--	104	110	mA
		15VDC/24VDC Output	--	103	110	mA
	Nominal voltage input@15VDC	3.3VDC Output	--	84	89	mA
		5VDC/7.2VDC Output	--	84	89	mA
		9VDC/12VDC Output	--	83	89	mA
		15VDC/24VDC Output	--	83	88	mA
	Nominal voltage input@24VDC	3.3VDC Output	--	56	61	mA
		5VDC/7.2VDC Output	--	53	58	mA
		9VDC/12VDC Output	--	53	58	mA
		15VDC/24VDC Output	--	52	58	mA
Input current (No-load)			--	5	30	mA
Reflected ripple current			--	15	--	mA
Input impulse voltage	1sec. max.	3.3VDC/5VDC Input	-0.7	--	9	VDC
		9VDC Input	-0.7	--	12	VDC
		12VDC Input	-0.7	--	18	VDC
		15VDC Input	-0.7	--	21	VDC
		24VDC Input	-0.7	--	30	VDC
Input filter	Capacitive filtering					
Remarks/: <b>This product does not support hot plug</b>						

## Output Characteristic

Parameter	Conditions	Min.	Typ.	Max.	Units	
Output voltage accuracy		See Figure 3 (envelope curve)				
Linear regulation rate	Input voltage variation +/- 1%	3.3VDC Output	--	--	+/-1.5	%
		Other outputs	--	--	+/-1.2	%
Load regulation rate	10% to 100% load	3.3VDC Output	--	15	20	%
		5VDC Output	--	10	15	%
		9VDC Output	--	8	10	%
		12VDC Output	--	7	10	%
		15VDC Output	--	6	10	%
		24VDC Output	--	5	10	%
Ripple & Noise	20MHz bandwidth	--	30	100	mVp-p	
Temperature drift coefficient	100% load	--	+/-0.03	--	%/°C	
Short circuit protection	Sustainable, Self-healing					
Note: The testing method for ripple and noise is the parallel line testing method.						

## General Characteristics

Parameter	Conditions	Min.	Typ.	Max.	Units
Isolation voltage	Input-output, Test time 1 minute, Leakage current less than 1 mA	1500	--	--	VDC
Insulation resistance	Input-output, Insulation voltage 500VDC	1000	--	--	MΩ
Isolation capacitance	Input-output, 100KHz/0.1V	--	20	50	pF
Working temperature	Temperature ≥ 85 °C for derating (See Figure 4)	-40	--	+105	°C
Storage temperature		-55	--	+125	°C
Storage humidity	Non condensing	--	--	95	%RH

Parameter	Conditions	Min.	Typ.	Max.	Units
Housing temperature rise during operation	Ta=25 °C, Nominal input, Full output	--	15	25	°C
Soldering temperature resistance of pins	The distance from the welding spot to the shell is 1.5mm, 10 seconds	--	--	300	°C
	REFLOW: Peak temperature Tc ≤ 245 °C, maximum time above 217 °C for 60 seconds.	--	--	245	°C
Switching frequency	Full load, Nominal input voltage	--	270	--	kHz
Mean time between failures 【MTBF】	MIL-HDBK-217F@25°C	3500	--	--	kHours

### Physical Characteristics

Parameter	Content
Housing material	Black flame retardant and heat-resistant plastic (UL94V-0)
Overall dimensions	13.20*11.40*7.25mm (Length * Width * Height)
Weight	1.4g(Typ.)
Cooling mode	Natural air cooling

### EMC Characteristics

Parameter	Category	Content
EMI	Conductive disturbance	CISPR32/EN55032 CLASS B (The recommended circuit is shown in Figure 2)
	Radiation disturbance	CISPR32/EN55032 CLASS B (The recommended circuit is shown in Figure 2)
EMS	Electrostatic discharge	IEC/EN61000-4-2 Contact ±4kV perf. Criteria B

### Circuit Design and Application

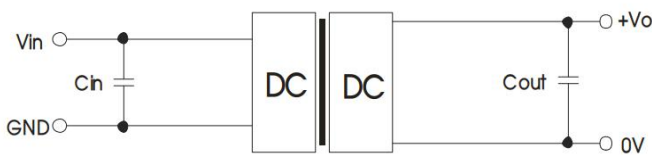

Figure 1: Application circuit

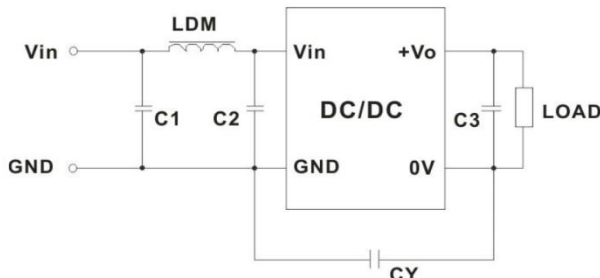

Figure 2: EMC Typical Recommended Circuits

Table 1: Recommended Capacitive Load Values

Vin(VDC)	Cin(μF)	Vo(VDC)	Cout(μF)
12VDC	2.2μF/25V	±3.3/±5VDC	10μF/16V
		±9VDC	2.2μF/16V
		±12VDC	2.2μF/25V
		±12VDC	1μF/25V
		±24VDC	1μF/50V

Table 2: Recommended Circuit Parameter Values

Category	Component	Value
EMI	C1	4.7μF /50V
	C2	4.7μF /50V
	C3	Refer to Cout parameter in Table 2
	CY	270pF/2kV
	LDM	6.8μH

### Product Characteristic Curve

1. Typical application: If further reduction of input and output ripple is required, a capacitor filter network can be connected at the input and output ends. The application circuit is shown in Figure 1. However, suitable filter capacitors should be selected. If the capacitance is too large, it may cause overcurrent or poor startup of the power supply. For each output, while ensuring safe and reliable operation, the recommended capacitance load values are shown in Table 1.
2. EMC requirements: For situations with high EMC requirements, a typical EMC recommended circuit is shown in Figure 2.
3. Input requirements: Ensure that the fluctuation range of the input voltage does not exceed the upper and lower limits of the input voltage specified in this data sheet, and the input power must be greater than the output power specified in this data sheet. For situations with a 24V input voltage, it is recommended to connect a TVS tube between the positive and negative input pins for protection (recommended parameters for TVS tubes: 30V, bidirectional, SOD-123 packaging).
4. Output load requirements: Try to avoid using it without load as much as possible; When the actual power of the load is less than 10% of the rated output power in this data sheet, or when it needs to be used in no-load situations, it is recommended to connect a load resistor externally at the output end. The load resistor can be calculated according to 5-10% of the rated power in this data sheet. The calculation formula for the load resistor value is  $R_L = U_{out}^2 / (P_{out} * 10\%)$ .
5. Overload protection: Under normal working conditions, the output circuit of this product has no protection function for overload situations. The simplest method is to connect a self recovery fuse in series at the input end, or add a circuit breaker outside the circuit; Or during design and selection, the actual power of the circuit should be around 60-80% of the rated power in this data sheet.

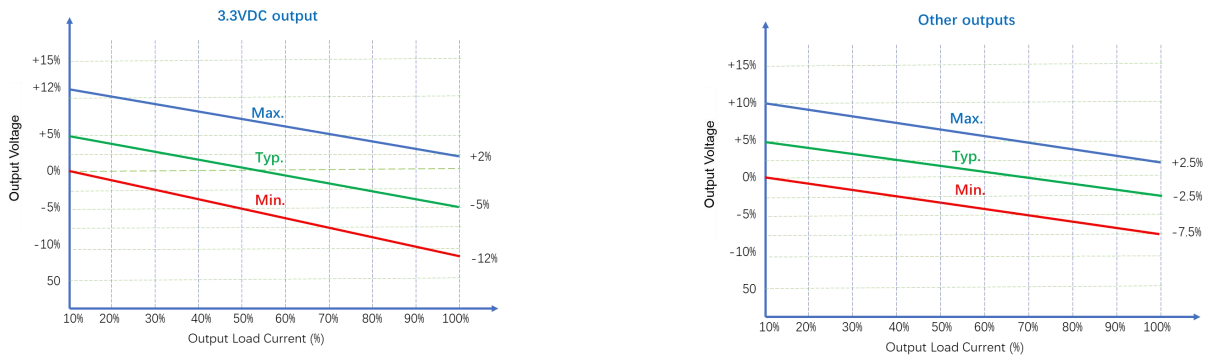

Figure 3: Voltage tolerance envelope

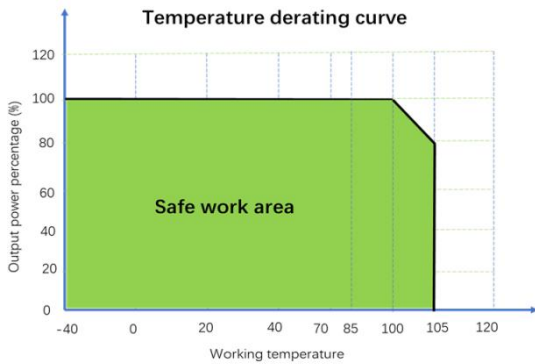

Figure 4: Temperature Derating Curve

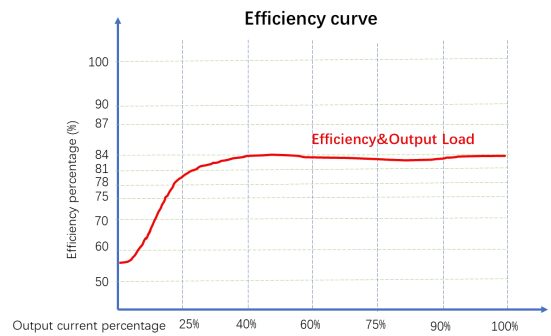

Figure 5: Efficiency VS Output Load (Nominal Voltage Input)

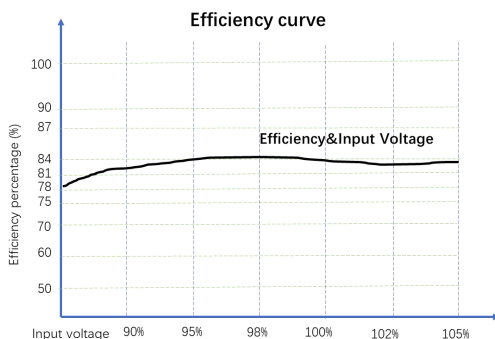
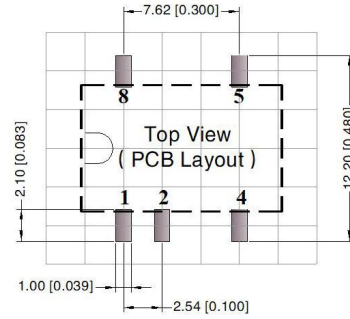
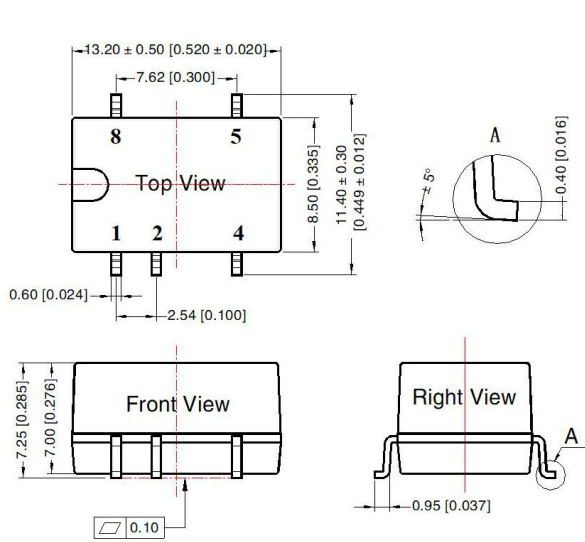

Figure 6: Efficiency VS Input Voltage (100% Load)

## Overall Dimensions and Pin Functions



Note: Grid 2.54\*2.54mm

Table 3: Pin Function Table

Pin	Function
1	GND
2	Vin
4	0V
5	+Vo
8	NC

**Note:**

Dimensions in mm

Terminal diameter tolerance:  $\pm 0.10$  [ $\pm 0.004$ ]

Undeclared tolerance:  $\pm 0.50$  [ $\pm 0.010$ ]

## Notes & Instructions

1. The input voltage shall not exceed the specified range value, otherwise permanent and unrecoverable damage may be caused;
2. Unless otherwise specified, the parameters in this manual are measured at 25 °C, 40%~75% humidity, input nominal voltage and output pure resistance mode under full load;
3. All index test methods are based on the company's enterprise standards.
4. The copyright and the final interpretation right of the product belong to AMCHARD.

**GUANGZHOU AMCHARD-POWER TECHNOLOGY CO., LTD.**

www.amchard-power.com

Mail:info@amchard-power.com