

FEATURES

1. Continuous short-circuit protection
2. No-load input current as low as 8mA
3. Operating ambient temperature range: -40°C to +105°C
4. High efficiency up to 81%
5. High power density
6. I/O isolation test voltage: 1.5k VDC
7. Industry standard pin-out
8. DIP Package



3 years
Warranty

Selection Guide

| Part No. | Input Voltage (VDC) | Output | | Full Load Efficiency (%) Min./Typ. | Capacitive Load* (µF) Max. |
|---------------|---------------------|---------------|------------------------|------------------------------------|----------------------------|
| | Nominal (Range) | Voltage (VDC) | Current (mA) Max./Min. | | |
| AMA0503D-1WR3 | 5 (4.5-5.5) | ±3.3 | ±152/±15 | 70/74 | 1200 |
| AMA0505D-1WR3 | | ±5 | ±100/±10 | 76/80 | 1200 |
| AMA0509D-1WR3 | | ±9 | ±56/±6 | 77/81 | 470 |
| AMA0512D-1WR3 | | ±12 | ±42/±5 | 77/81 | 220 |
| AMA0515D-1WR3 | | ±15 | ±34/±4 | 77/81 | 220 |
| AMA1205D-1WR3 | 12 (10.8-13.2) | ±5 | ±100/±10 | 76/80 | 1200 |
| AMA1212D-1WR3 | | ±12 | ±42/±5 | 77/81 | 280 |
| AMA1224D-1WR3 | | ±24 | ±21/±2 | 76/80 | 110 |
| AMA1524D-1WR3 | 15 (13.5-16.5) | ±24 | ±21/±2 | 77/81 | 110 |
| AMA2409D-1WR3 | 24 (21.6-26.4) | ±9 | ±56/±6 | 74/80 | 500 |
| AMA2412D-1WR3 | | ±12 | ±42/±4 | 75/81 | 280 |
| AMA2415D-1WR3 | | ±15 | ±33/±3 | 73/79 | 280 |

Note: * The specified maximum capacitive load for positive and negative output is identical.

Input Specifications

| Item | Operating Conditions | Min. | Typ. | Max. | Unit | |
|----------------------------------------|----------------------|-------------------------|--------------------|-------|--------|----|
| Input Current (full load / no-load) | 5VDC input | 3.3VDC output | - | 270/8 | 286/-- | mA |
| | | 5VDC output | - | 251/8 | 264/-- | |
| | | 9VDC/12VDC/15VDC output | - | 247/8 | 260/-- | |
| | 12VDC input | 5VDC output | - | 104/8 | 110/-- | |
| | | 12VDC output | - | 103/8 | 109/-- | |
| | | 24VDC output | - | 104/8 | 110/-- | |
| | 15VDC input | | - | 83/8 | 87/-- | |
| | 24VDC input | 9VDC output | - | 52/8 | 57/-- | |
| | | 12VDC output | - | 52/8 | 56/-- | |
| 15VDC output | | - | 53/8 | 58/-- | | |
| Reflected Ripple Current* | | - | 15 | - | | |
| Surge Voltage (1sec. max.) | 5VDC input | -0.7 | - | 9 | VDC | |
| | 12VDC input | -0.7 | - | 18 | | |
| | 15VDC input | -0.7 | - | 21 | | |
| | 24VDC input | -0.7 | - | 30 | | |
| Input Filter | | | Capacitance filter | | | |

| | | |
|----------------------------------------------------------------------------------------------------------------------|--|-------------|
| Hot Plug | | Unavailable |
| Note: * Refer to DC-DC Converter Application Notes for detailed description of reflected ripple current test method. | | |

Output Specifications

| Item | Operating Conditions | | Min. | Typ. | Max. | Unit | |
|-----------------------------------------------------------------------------------------------------------------------------------------------------|---------------------------|-------------|--------------------------------------|-------|------|-------|---|
| Voltage Accuracy | | | See output regulation curve (Fig. 1) | | | | |
| Linear Regulation | Input voltage change: ±1% | | 3.3VDC output | - | - | 1.5 | - |
| | | | Other output | - | - | 1.2 | |
| Load Regulation | 10%-100% load | 5VDC input | 3.3VDC output | - | 15 | 20 | % |
| | | | 5VDC output | - | 10 | 15 | |
| | | | 9VDC output | - | 9 | 10 | |
| | | | 12VDC output | - | 8 | 10 | |
| | | | 15VDC output | - | 7 | 10 | |
| | | Other input | 5VDC output | - | - | 15 | |
| | | | 9VDC output | - | - | 10 | |
| | | | 12VDC output | - | - | 10 | |
| | | | 15VDC output | - | - | 10 | |
| | | | 24VDC output | - | - | 10 | |
| Ripple & Noise* | 20MHz bandwidth | | - | 50 | 100 | mVp-p | |
| Temperature Coefficient | Full load | | - | ±0.02 | - | %/°C | |
| Short-circuit Protection | | | Continuous, self-recovery | | | | |
| Notes: * The "parallel cable" method is used for Ripple and Noise test, please refer to DC-DC Converter Application Notes for specific information. | | | | | | | |

General Specifications

| Item | Operating Conditions | | Min. | Typ. | Max. | Unit |
|--------------------------------------|-------------------------------------------------------------------------------------|---------------|----------------------------------------|------|------|---------|
| Isolation | Input-output electric strength test for 1 minute with a leakage current of 1mA max. | | 1500 | - | - | VDC |
| Insulation Resistance | Input-output resistance at 500VDC | | 1000 | - | - | MΩ |
| Isolation Capacitance | Input-output capacitance at 100kHz/0.1V | | - | 20 | - | pF |
| Operating Temperature | Derating when operating temperature ≥ 85°C (see Fig. 2) | | -40 | - | 105 | °C |
| Storage Temperature | | | -55 | - | 125 | |
| Case Temperature Rise | Ta=25°C | 3.3VDC output | - | 25 | - | |
| | | Other output | - | 15 | - | |
| Pin Soldering Resistance Temperature | Soldering spot is 1.5mm away from case for 10 seconds | | - | - | 300 | |
| Storage Humidity | Non-condensing | | 5 | - | 95 | %RH |
| Vibration | | | 10-150Hz, 5G, 0.75mm, along X, Y and Z | | | |
| Switching Frequency | 100% load, nominal input voltage | 5VDC input | - | 300 | - | kHz |
| | | Other input | - | 260 | - | |
| MTBF | MIL-HDBK-217F@25°C | | 3500 | - | - | k hours |

Mechanical Specifications

| | |
|-----------------------|--------------------------------------------------------------|
| Case Material | Black plastic; flame-retardant and heat-resistant (UL94 -V0) |
| Dimensions | 19.50 x 9.80 x 7.90 mm |
| Weight | 2.4g(Typ.) |
| Cooling Method | Free air convection |

EMC Specifications

| | | |
|-----------------------------------------------------|-----|---------------------------------------------------------|
| Emissions | CE | CISPR32/EN55032 CLASS B |
| | RE | CISPR32/EN55032 CLASS B |
| Immunity | ESD | IEC/EN61000-4-2 Air ±8kV, Contact ±6kV perf. Criteria B |
| Note: Refer to Fig. 4 for recommended circuit test. | | |

Typical Characteristic Curves

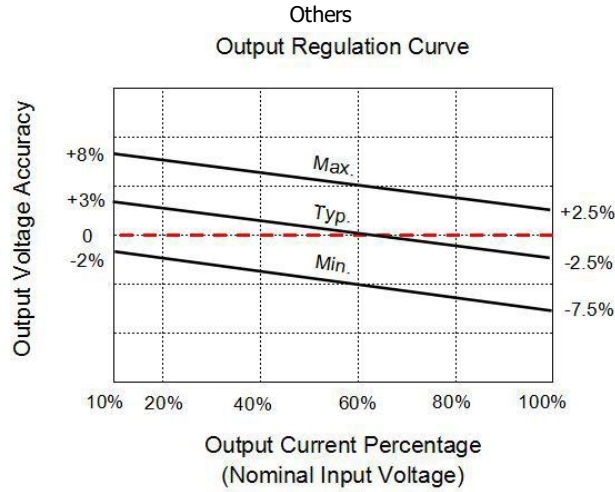
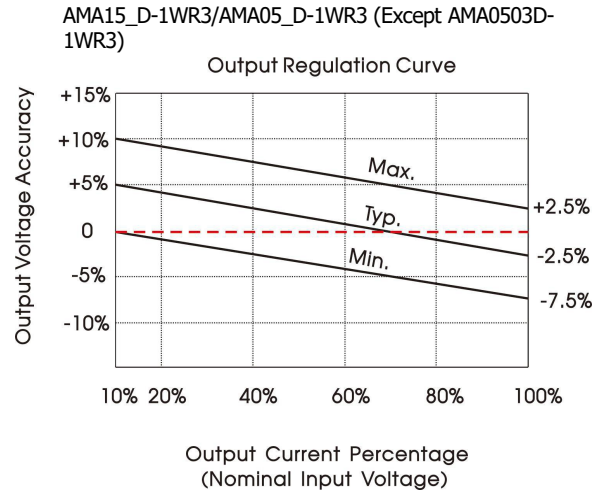
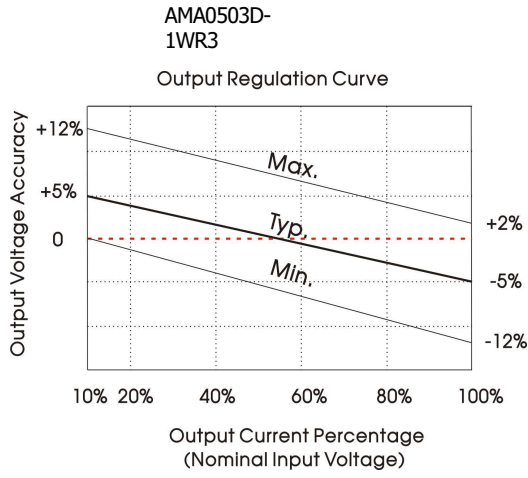

Fig. 1

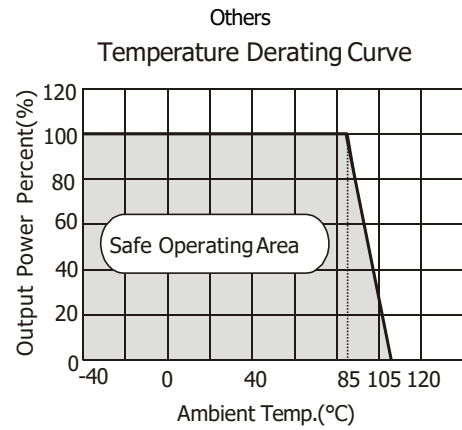
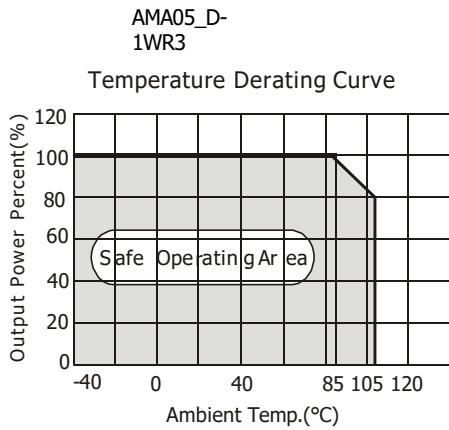
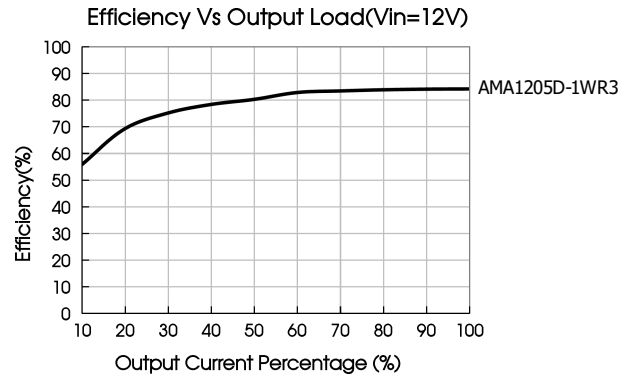
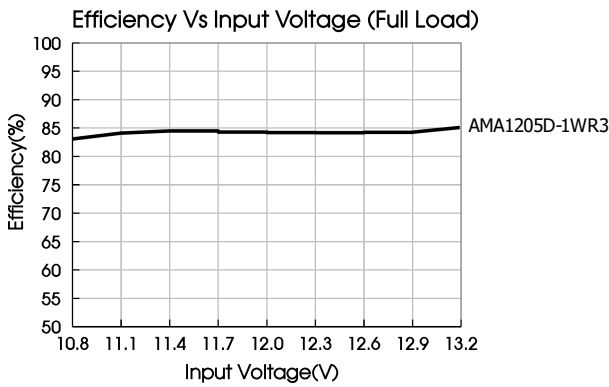
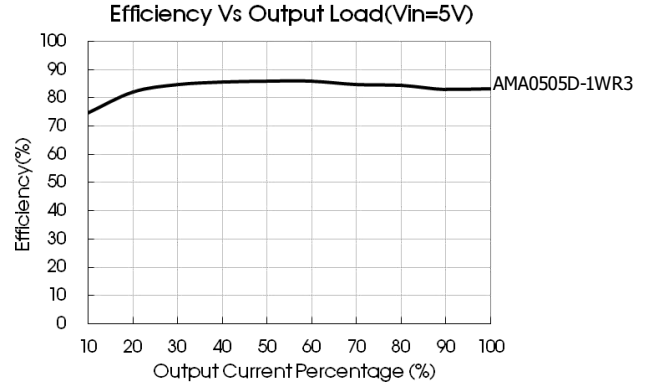
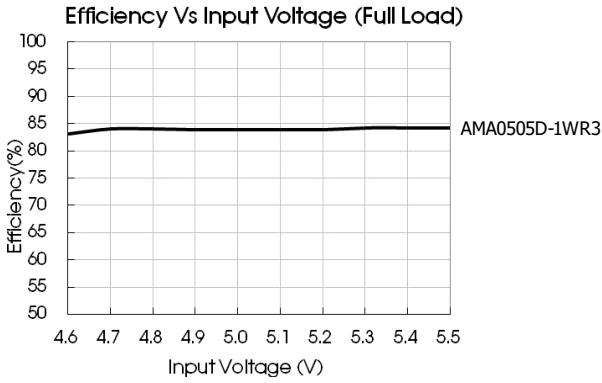

Fig. 2



Design Reference

1. Typical application

Input and/or output ripple can be further reduced, by connecting a filter capacitor from the input and/or output terminals to ground as shown in Fig. 3. Choosing suitable filter capacitor values is very important for a smooth operation of the modules, particularly to avoid start-up problems caused by capacitor values that are too high. For recommended input and output capacitor values refer to Table 1.

Table 1: Recommended input and output capacitor values



Fig. 3

| Vin | Cin | Vout | Cout* |
|-------|-----------|---------------|------------|
| 5VDC | 4.7μF/16V | ±3.3VDC/±5VDC | 4.7μF/16V |
| - | - | ±9/±12VDC | 1μF/25V |
| - | - | ±15VDC | 0.47μF/50V |
| 12VDC | 2.2μF/25V | ±5VDC/±9VDC | 4.7μF/16V |
| 15VDC | 2.2μF/25V | ±12VDC/±15VDC | 1μF/25V |
| 24VDC | 1μF/50V | ±24VDC | 0.47μF/50V |

Note: *The capacitor value of the positive and the negative output is identical.

2. EMC compliance circuit

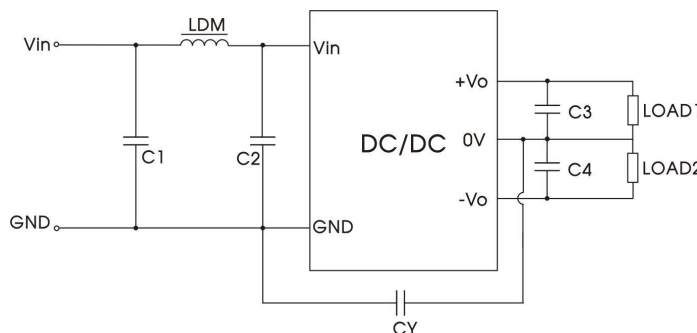

Fig. 4

EMC recommended circuit value table (Table 2)

| Input voltage | | 5VDC | | Others |
|----------------|-------|------------------------------|---------------|-----------------|
| Output voltage | | 3.3/5/9VDC | 12/15VDC | 5/9/12/15/24VDC |
| Emissions | C1/C2 | 4.7μF /25V | 4.7μF /25V | 4.7μF /50V |
| | CY | 100pF /2kVDC | 1000pF /2kVDC | 270pF /2kVDC |
| | C3/C4 | Refer to the Cout in table 1 | | |
| | LDM | 6.8μH | | |

Note: In the case of actual use, the requirements for EMI are high, it is subject to CY.

Dimensions and Recommended Layout

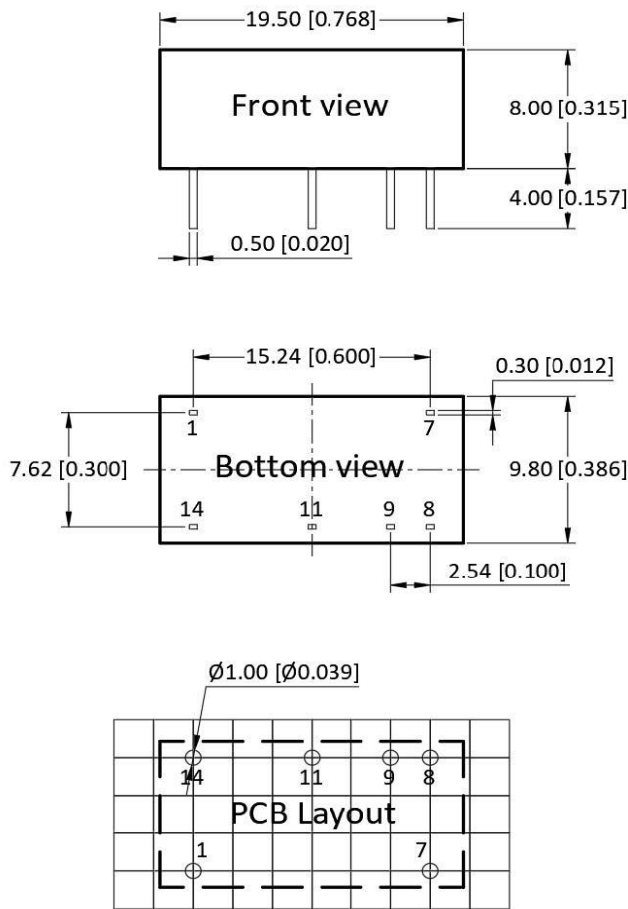

Pin Definition

| Pin | Single Out | Dual Out |
|-----|------------|----------|
| 1 | GND | GND |
| 7 | NC | NC |
| 8 | -VOUT | 0V |
| 9 | +VOUT | +VOUT |
| 11 | No Pin | -VOUT |
| 14 | VIN | VIN |

- * Unless otherwise specified unit: mm [inch]
- * General tolerance: ± 0.25 [± 0.010]
- * Pin thickness: ± 0.10 [± 0.004]
- * Footprint grid 2.54 x 2.54 mm

Note:

1. If the product works under the minimum required load, it cannot guarantee that the performance of the product complies with all the performance indicators in this manual;
2. The maximum capacitive load is tested under the input voltage range and full load condition;
3. Unless otherwise stated, all indexes in this manual are measured at $T_a=25^\circ\text{C}$, humidity $<75\%\text{RH}$, nominal input voltage and rated output load;
4. All index testing methods in this manual are based on the enterprise standards of the company;
5. Our company can provide product customization, specific needs can directly contact our technical staff;