

Product Feature

1. Package Type: 1"X1"
2. Input voltage range: 2:1
3. Operating temperature range: -40°C - +85°C
4. Isolation voltage: 1500VDC
5. High Efficiency: 88% (Typ.)
6. Output short-circuit protection and overcurrent protection.
7. Fields of application: Power, Industrial control, Communications, Internet of things, Automotive.

3 years Warranty

Selection Guide

Part No.	Input Voltage (VDC)		Output		Full Load Efficiency(%) Min./Typ.	Capacitive Load (μF)Max.
	Nominal (Range)	Max.	Voltage (VDC)	Current(mA) Max./Min.		
GTA0505YMD-10WR3	5 (4.5-9)	12	±5	±1000/0	76/78	1000
GTA0512YMD-10WR3			±12	±417/0	81/83	470
GTA0515YMD-10WR3			±15	±334/0	82/84	330
GTA0524YMD-10WR3			±24	±209/0	81/83	100
GTB0503YMD-10WR3			3.3	2500/0	82/84	470
GTB0505YMD-10WR3			5	2000/0	83/85	470
GTB0512YMD-10WR3			12	834/0	81/83	470
GTB0515YMD-10WR3			15	667/0	82/84	330
GTB0524YMD-10WR3			24	417/0	81/83	100
GTB1205YMD-10WR3			12 (9-18)	20	5	2000/0
GTB2403YMD-10WR3	24 (18-36)	40	3.3	2400/0	78/82	2200
GTB2405YMD-10WR3			5	2000/0	80/82	2200
GTB2412YMD-10WR3			12	833/0	85/87	470
GTB2415YMD-10WR3			15	667/0	85/87	330
GTB2424YMD-10WR3			24	416/0	86/88	100
GTB4803YMD-10WR3	48 (36-75)	80	3.3	2400/0	77/79	2200
GTB4805YMD-10WR3			5	2000/0	81/83	2200
GTB4812YMD-10WR3			12	833/0	85/87	470
GTB4815YMD-10WR3			15	667/0	85/87	330
GTB4824YMD-10WR3			24	416/0	86/88	100

Input Specifications

Item	Operating Conditions	Min.	Typ.	Max.	Unit	
Input Current (full load/no-load)	24VDC nominal input series	3.3VDC Output	--	423/5	434/12	mA
		Other Output	--	502/5	514/12	
	48VDC nominal input series	3.3VDC Output	--	190/4	215/8	mA
		Other Output	--	251/4	258/11	
Reflected Ripple Current	24VDC nominal input series	--	40	--	mA	
	48VDC nominal input series	--	30	--		
Impulse Voltage	24VDC Input	-0.7	--	50	VDC	
	48VDC Input	-0.7	--	100		
Starting Voltage	24VDC Input	--	--	9	VDC	
	48VDC Input	--	--	18		
Input undervoltage protection	24VDC Input	5.5	6.5	--	VDC	
	48VDC Input	12	15.5	--		
Start time	Nominal input and constant resistance load	--	10	--	ms	
Ctrl	Turn off module	connected GND or (0-1.2V)				
	Turn on module	No connected or (3.5-12V)				
Input Filter		PI filter				
Hot Plug		Unavailable				

Output Specifications

Item	Operating Conditions	Min.	Typ.	Max.	Unit	
Output Voltage Accuracy	0%-100% load	--	±1	±3	%	
Linear Regulation	Input voltage from low limit to high limit, full load	Vo1	--	±0.2	±0.5	%
		Vo2	--	±0.5	±1	
Load Regulation	5%- 100% load	Vo1	--	±0.5	±1	%
		Vo2	--	±0.5	±1.5	
Ripple & Noise	20MHz bandwidth,5%-100% load	--	40	80	mVp-p	
Cross adjustment rate	Dual output, with 50% load on the main circuit and 10% - 100% load on the secondary circuit	--	--	±5	%	
Transient Recovery Time	25% Load Step Change, nominal input voltage	--	300	500	µs	
Transient Response Deviation	25% Load Step Change, nominal input voltage	--	±3	±5	%	
Temperature Coefficient	Full Load	--	--	±0.03	%/°C	
Over Voltage Protection	Input voltage range	110	--	160	%Vo.	
Over Current Protection	Input voltage range	110	140	--	%Io	
Short-Circuit Protection	Input voltage range	Continuous, Self-Recovery				

General Specifications

Item	Operating Conditions	Min.	Typ.	Max.	Unit
Isolation Voltage	Input-output, test time 1 minute, leakage current less than 1mA	1500	--	--	VDC
Insulation Resistance	Input-output, insulated voltage 500VDC	1000	--	--	MΩ
Isolation Capacitance	Input-output, 100KHz/0.1V	--	2000	--	pF
Operating Temperature	See Fig 1	-40	--	+85	°C
Storage Temperature		-55	--	+125	°C
Storage Humidity	Non-condensing	5	--	95	%RH
Soldering Profile	1.5mm from case for 10 sec	--	--	300	°C
Switching Frequency	PWM	--	300	--	kHz
MTBF	MIL-HDBK-217F@25°C	1000	--	--	K Hours
Vibration		IEC/EN 61373 Vehicle Body 1 Class B			

Mechanical Specifications

Case Material	Aluminum alloy, black anodized coating
Package Dimensions	25.4 X 25.40 X 12.00 mm
Weight	15.00g (Typ.)
Cooling Method	Free air convection

EMC Specifications

EMI	CE	CISPR32/EN55032 CLASS A (without extra components)/ CLASS B (Recommended circuit diagram 3-②)		
	RE	CISPR32/EN55032 CLASS A (without extra components)/ CLASS B (Recommended circuit diagram 3-②)		
EMS	ESD	IEC/EN61000-4-2	Contact±4KV/Air ±6KV	Perf.Criteria B
	RS	IEC/EN61000-4-3	10V/m	Perf.Criteria A
	EFT	IEC/EN61000-4-4	±2KV (Recommended circuit diagram 3-①)	Perf.Criteria B
	Surge	IEC/EN61000-4-5	line to line±2KV(Recommended circuit diagram 3-①)	Perf.Criteria B
	CS	IEC/EN61000-4-6	3Vr.m.s	Perf.Criteria A

Typical Characteristic Curves

Temperature Derating Curve (Figure 1)

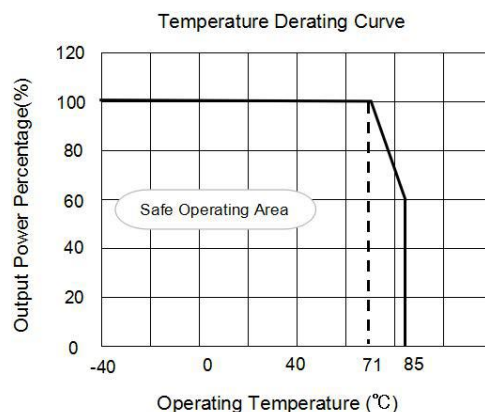

5VDC input series, except 3.3VDC output

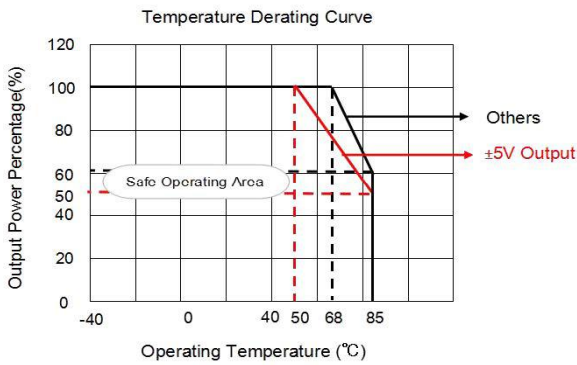

Others

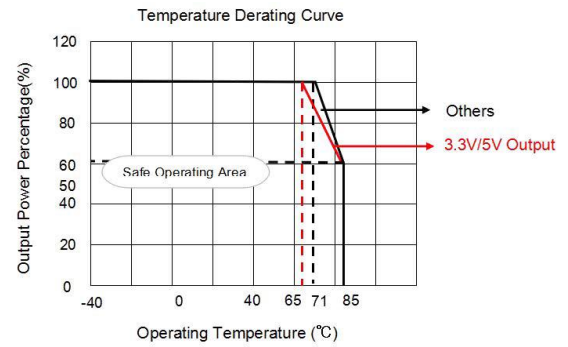

Efficiency Vs Input Voltage(Full Load)

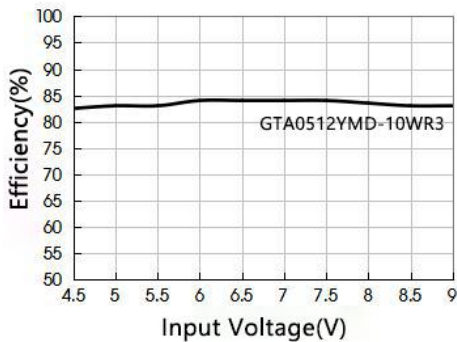

Efficiency Vs Output Load(Vin=5V)

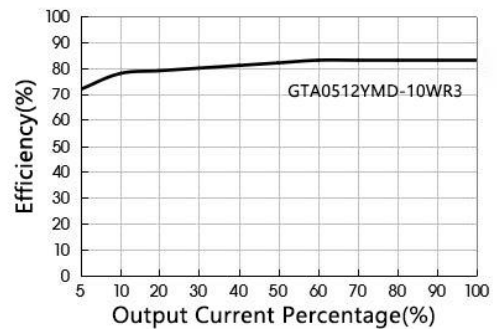

Typical Circuit Design And Application

Figure2

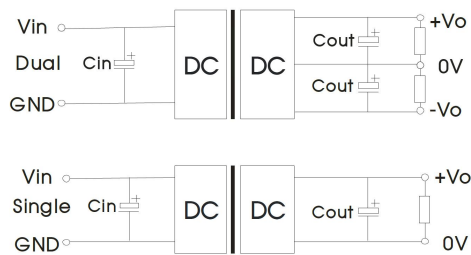

Recommended component parameters

Vout(VDC)	Cin(μ F)	Cout(μ F)
3.3/5/12/15	100 μ F	100 μ F
24	100 μ F	47 μ F

Figure 3

EMI Recommended component parameters

24VDC/48VDC nominal input series

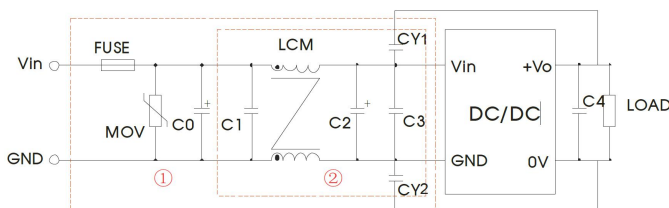

Note: Part ① of Figure 3 is used for EMS testing; Part 2 is used for EMI filtering and can be selected according to requirements.

Model	Vin:24VDC	Vin:48VDC
FUSE	Select fuse value according to actual input current	
MOV	S20K30	S14K60
C0	680 μ F/50V	680 μ F/100V
C1	1 μ F/50V	1 μ F/100V
C2	330 μ F/50V	330 μ F/100V
C3	4.7 μ F/50V	4.7 μ F/100V
C4	Refer to the Cout in Fig.2	
LCM	4.7mH	
CY1,CY2	1nF/2kV	

All DC-DC converters of this series are tested before delivery using the recommended circuit shown in Fig. 2. Input and/or output ripple can be further reduced by appropriately increasing the input & output capacitor values Cin and Cout and/or by selecting capacitors with a low ESR (equivalent series resistance). Also make sure that the capacitance is not exceeding the specified max. capacitive load value of the product.

Dimensions and Recommended Layout

Dimensions

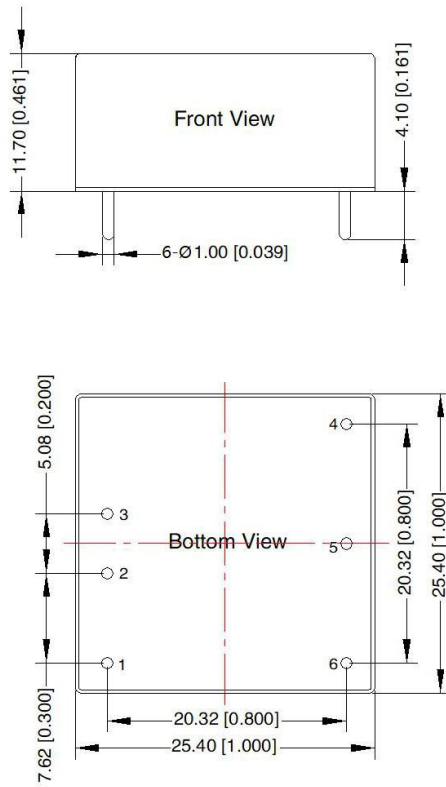

PCB Printing Layout

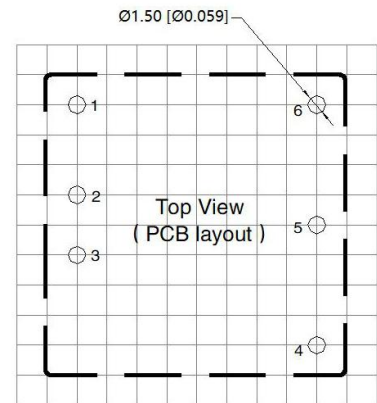

Pin Definition Table

Pin	Single	Dual
1	CTRL	CTRL
2	GND	GND
3	Vin	Vin
4	+Vo	+Vo
5	No Pin	0V
6	0V	-Vo

Note:

Unit: mm[inch]
 Pin section tolerances: ±0.10 [±0.004]
 General tolerances: ±0.50 [±0.020]

Note:

1. The input voltage should not exceed the specified range value, otherwise it may cause permanent and irreparable damage;
2. It is recommended to use at a load of over 5%. If the load is below 5%, the ripple index of the product may exceed the specifications, but it does not affect the reliability of the product;
3. Suggested dual output module load imbalance: ≤ ± 5%. If it exceeds ± 5%, it cannot be guaranteed that the product performance meets all performance indicators in this manual;
4. The maximum capacitive load is tested within the input voltage range and under full load conditions;
5. Unless otherwise specified, all indicators in this manual are measured at Ta=25 °C, humidity<75% RH, nominal input voltage, and output rated load;
6. All indicator testing methods in this manual are based on our company's corporate standards;
7. Our company can provide product customization, and specific requirements can be directly contacted by our technical personnel;
8. Product specifications are subject to change without prior notice.