

Product Feature

1. Package Type: 1 * 1
2. Operating Temperature Range: -40°C - +85°C
3. Isolation Voltage: 1500VDC
4. Wide Input Voltage Range: 4: 1
5. High efficiency up to 88%
6. With the output overcurrent, output short circuit protection mechanism
7. Fields of application: electric power, industrial control, etc
8. Input reverse polarity protection available with A4S



3 years Warranty

Selection Guide

Part No.	Input Voltage (VDC)		Output		Full Load Efficiency% (Min./Typ.)	Capacitive Load Max. (µF)
	Nominal (Range)	Maximum	Voltage (VDC)	Current Max.(mA)		
ATB2403YMD-10WR3	24 (9-36)	40	3.3	2400/0	78	2200
ATB2405YMD-10WR3			5	2000/0	83	2200
ATB2409YMD-10WR3			9	1111/0	85	680
ATB2412YMD-10WR3			12	833/0	86	470
ATB2415YMD-10WR3			15	667/0	86	330
ATB2424YMD-10WR3			24	416/0	88	100
ATB2440YMD-10WR3			40	250/0	87	
ATA2405YMD-10WR3			±5	±1000/0	83	#1000
ATA2409YMD-10WR3			±9	±555/0	86	#680
ATA2412YMD-10WR3			±12	±416/0	87	#470
ATA2415YMD-10WR3			±15	±333/0	87	#330
ATA2424YMD-10WR3			±24	±208/0	87	#100
ATB4803YMD-10WR3			48 (18-75)	80	3.3	2400/0
ATB4805YMD-10WR3	5	2000/0			83	2200
ATB4812YMD-10WR3	12	833/0			87	470
ATB4815YMD-10WR3	15	667/0			87	330
ATB4848YMD-10WR3	24	416/0			88	100
ATA4805YMD-10WR3	±5	±1000/0			83	#1000
ATA4812YMD-10WR3	±12	±416/0			87	#470
ATA4815YMD-10WR3	±15	±333/0/			87	#330
ATA4848YMD-10WR3	±24	±208/0			87	#100

Input Specifications

Item	Operating Conditions		Min.	Typ.	Max.	Unit
Input Current (full load/no load)	24VDC Input	3.3V output	--	423/5	434/12	mA
		Other	--	502/5	514/12	
	48VDC Input	3.3V output	--	190/4	215/8	
		Other	--	251/4	258/11	
Reflected Ripple Current	24VDC Input		--	40	--	
	48VDC Input		--	30	--	
Impulse Voltage	24VDC Input		-0.7	--	50	VDC
	48VDC Input		-0.7	--	100	
Starting Voltage	24VDC Input		--	--	9	
	48VDC Input		--	--	18	
Undervoltage Protection	24VDC Input		5.5	6.5	--	
	48VDC Input		12	15.5	--	
Start time			--	10	--	ms
Ctrl	turn off module		connected GND or (0-1.2V)			
	turn on module		No connected or (2.7-9V)			
Input Filter			PI filter			
Hot Plug			Unavailable			

Output Specifications

Item	Operating Conditions		Min.	Typ.	Max.	Unit
Output Voltage Accuracy	0% - 100% Load		--	±1	±3.0	%
Linear Regulation	Full load, Input voltage from low limit to high limit	Vo1	--	±0.2	±0.5	
		V02		±0.5	±1	
Load Regulation	5% - 100% Load	Vo1	--	±0.5	±1	
		V02		±0.5	±1.5	
Ripple & Noise	20MHZ Bandwidth		--	40	80	
Cross Regulation	Dual output, main road with 50% load, secondary road with 10%-100% load		--	--	±5	%
Transient Recovery Time	25% load step change		--	300	500	µs
Transient Response Deviation			--	±3	±5	%
Temperature Coefficient	Full Load		--	--	±0.03	%/°C

Over Current Protection	input voltage range	110	--	160	%Io
Over Voltage Protection		110	140	190	%Vo
Short-circuit Protection		Continuous, Self-Recovery			

General Specifications

Item	Operating Conditions	Min.	Typ.	Max.	Unit
Insulation Voltage	Input-output, test time 1 minute, leakage current less than 1mA	1500	--	--	VDC
Insulation Resistance	Input-output, insulated voltage 500VDC	1000	--	--	MΩ
Isolation Capacitance	Input-output, 100KHz/0.1V	--	1000	--	pF
Operating Temperature	(See Figure 1)	-40	--	+85	°C
Storage Temperature		-55	--	+125	
Storage Humidity	Non-condensing	5	--	95	%RH
Pin welding can withstand the highest temperature	Soldering spot is 1.5mm away from case for 10 seconds	--	--	300	°C
Switching Frequency	PWM pattern	--	300	--	kHz
MTBF	MIL-HDBK-217F@25°C	1000Kh			

Mechanical Specifications

Case Material	Aluminum alloy, black anodized coating	
Package Dimensions	Horizontal package	25.40×25.40×12.00mm
	A4S rail package	76.00×31.50×25.80mm
Weight	Horizontal package/ A4S rail package	15.00g/59.00g
Cooling Method	Free air convection	

EMC Specifications

EMI	CE	CISPR32/EN55032 CLASS A(open board)/CLASS B (application circuit 3-②)	
	RE	CISPR32/EN55032 CLASS A(open board)/CLASS B (application circuit 3-②)	
	ESD	IEC/EN61000-4-2 Contact±4KV,Air ±4KV	perf. CriteriaB
EMS	RS	IEC/EN61000-4-3 10V/m	perf. CriteriaA
	EFT	IEC/EN61000-4-4 ±2KV(application circuit3-①)	Perf.Criteria B

Surge	IEC/EN61000-4-5 line to line±2KV(application circuit3-④)	Perf.Criteria B
CS	IEC/EN61000-4-6 3 Vr.m.s	Perf.Criteria A
Voltage dips, drops and short interruption immunity	IEC/EN61000-4-6 3 Vr.m.s	Perf.Criteria B

Typical Characteristic Curves

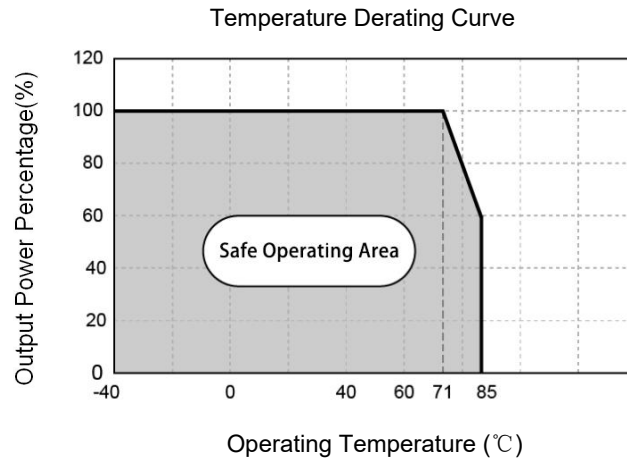
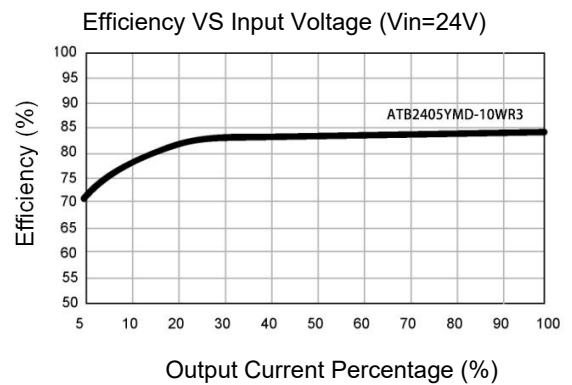
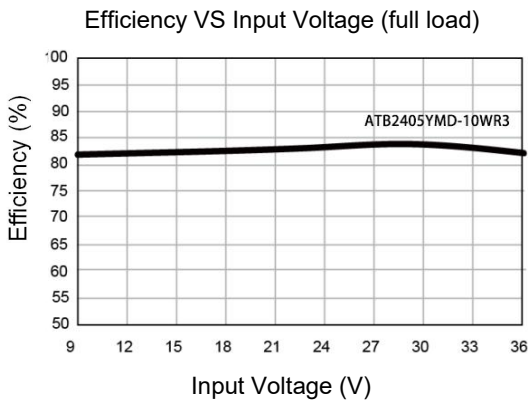
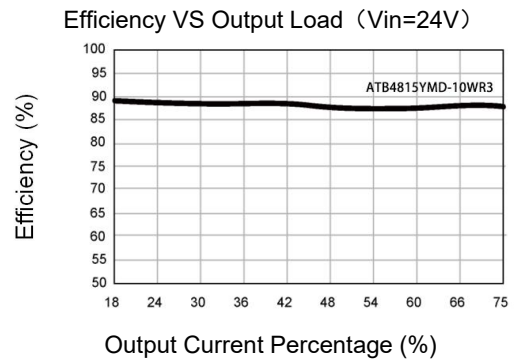
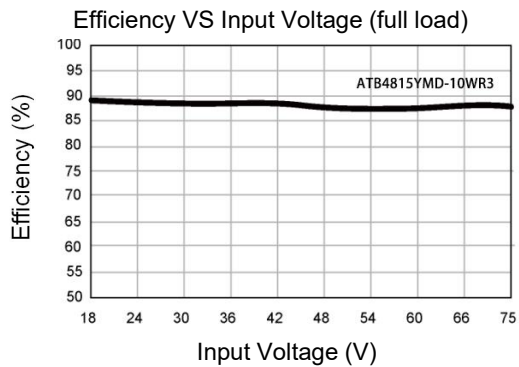

Figure 1



Circuit Design and Application

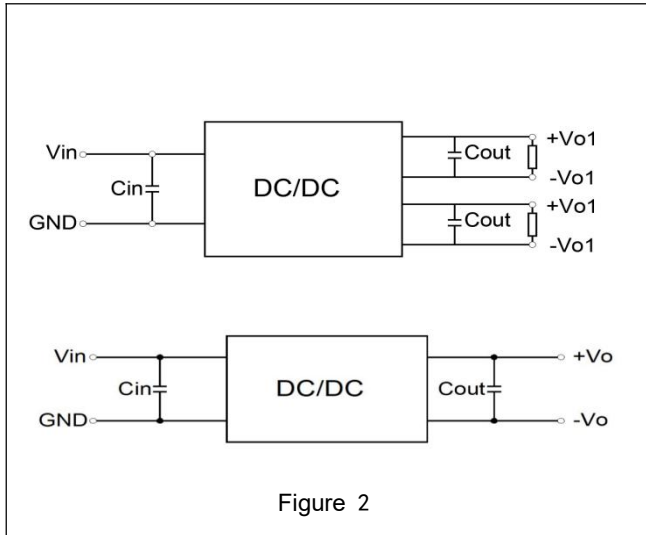

Figure 2

Recommended Capacitive Load Value Table		
Vin	24V	48V
Cin	100uF	10uF-47uF
Cout	10uF	

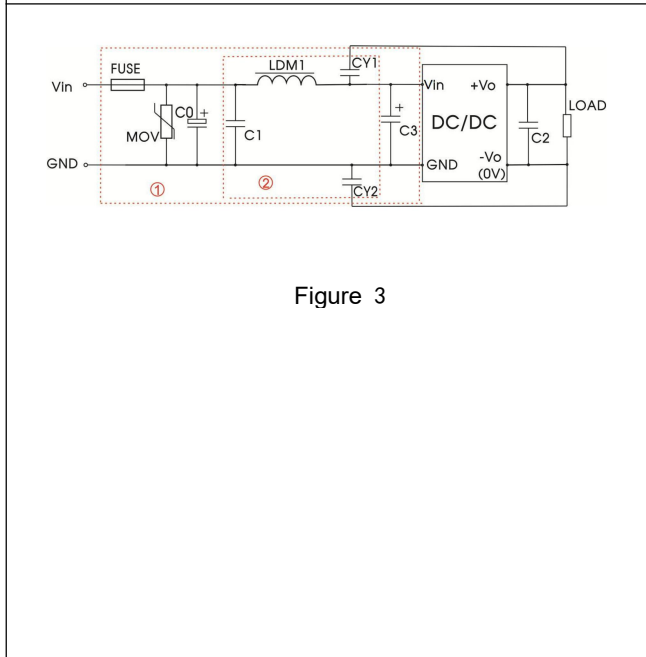
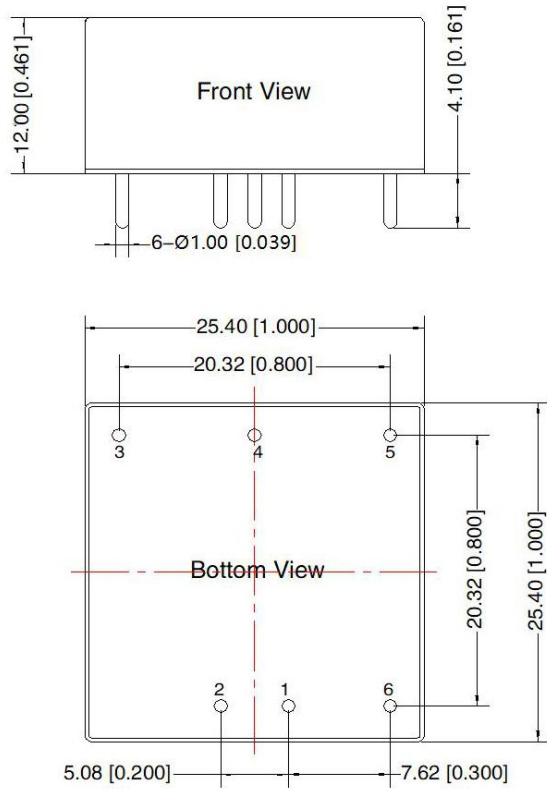

Figure 3

EMI Recommended Parameter Table		
Model	Vin: 24V	Vin: 48V
FUSE	Select according to the actual input current of the customer	
MOV	20D470K	14D101K
C0、C3	330uF/50V	330uF/100V
C1	1uF/50V	1uF/100V
C2	Refer to Figure 2 Cout parameter	
LDM1	4.7uH	
CY1、CY2	1nF/2KV	
Note: Part 1 in Figure 3 is for EMC testing; The second part is used for EMI filtering, which can be selected according to the demand.		

Dimensions and Recommended Layout

Dimensions



PCB Printing Layout & Pin Definition Table

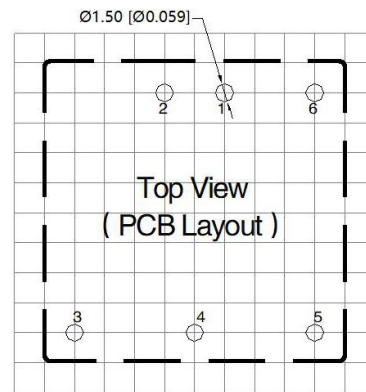

Note: The grid distance is 2.54mm*2.54mm

Note:

Unit: mm[inch]

Pin section tolerances: ± 0.10 [± 0.004]

General tolerances: ± 0.50 [± 0.020]

Pin	Function (single)	Function (double)
1	GND	GND
2	V _{in}	V _{in}
3	+V _o	+V _o
4	No Pin	COM
5	-V _o	-V _o
6	CTRL	CTRL

Dimensions and Recommended Layout

Dimensions	PCB Printing Layout & Pin Definition Table
-------------------	---

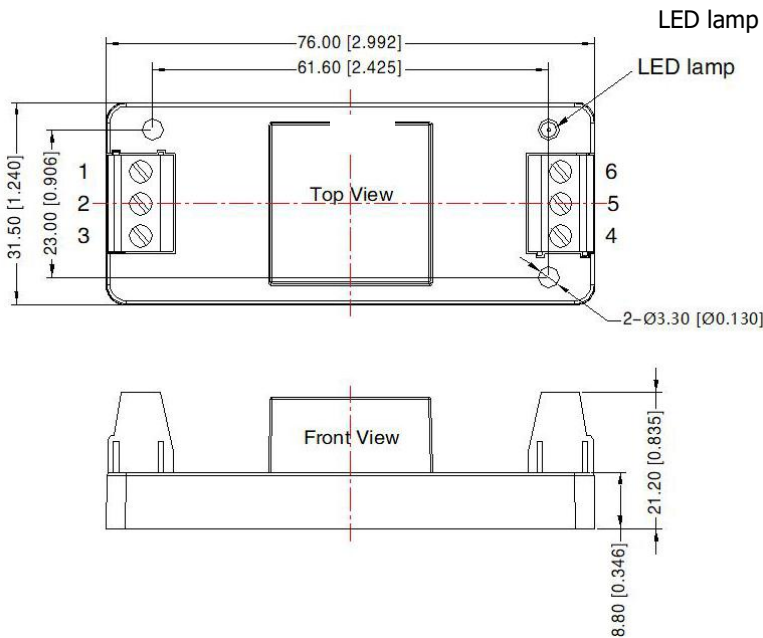

Pin	Function (single)	Function (double)
1	NC	NC
2	GND	GND
3	Vin	Vin
4	-Vo	-Vo
5	NC	COM
6	+Vo	+Vo

Note:

1. The input voltage cannot exceed the specified range value, otherwise permanent and irreparable damage may be caused ;
2. Unless otherwise specified, the parameters in this datasheet were measured at 25°C, humidity 40%~75%, input nominal voltage and output pure resistance mode under full load;
3. All index test methods are based on our company's enterprise standards.

GUANGZHOU AMCHARD-POWER TECHNOLOGY CO., LTD.

www.amchard-power.com

Mail:info@amchard-power.com