

FEATURES

1. Ultra-wide 4:1 input voltage range
2. High efficiency up to 86%
3. I/O isolation test voltage: 2250 VDC
4. Operating ambient temperature range: -40°C to +85°C
5. Input under-voltage protection, output short-circuit, over-current, over-voltage protection
6. Low ripple & noise
7. Input reverse polarity protection available with chassis(A2S) or Din-Rail mounting (A4S) version
8. Meets EN50155 railway standard
9. Industry standard pin-out

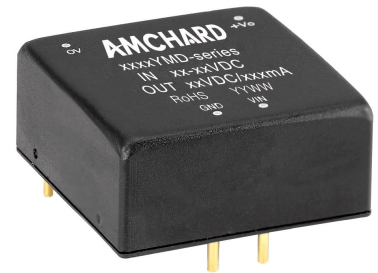

3 years Warranty

Selection Guide

Part No. ①	Input Voltage (VDC)		Output		Full Load Efficiency ④ (%) Min./Typ.	Capacitive Load ⑤ (μF)Max.
	Nominal ② (Range)	Max. ③	Voltage (VDC)	Current (mA) Max./Min.		
ATA1D05YMD-6WR3	110 (40-160)	170	±5	±600/0	80	470
ATA1D12YMD-6WR3			±12	±250/0	84	100
ATA1D15YMD-6WR3			±15	±200/0	85	100
ATB1D05YMD-6WR3			5	1200/0	80	1000
ATB1D12YMD-6WR3			12	500/0	84	470
ATB1D15YMD-6WR3			15	400/0	85	220
ATB1D24YMD-6WR3			24	250/0	86	100

Note:

- ① Use "H" suffix for heat sink mounting, "A2S" suffix for chassis mounting and "A4S" suffix for Din-Rail mounting. We recommend to choose modules with a heat sink for enhanced heat dissipation and applications with extreme temperature requirements;
- ② The minimum input voltage and starting voltage of A2S and A4S Model are 1VDC higher than those of DIP package due to input reverse polarity protection function;
- ③ Exceeding the maximum input voltage may cause permanent damage;
- ④ Efficiency is measured at nominal input voltage and rated output load; efficiencies for A2S and A4S Model's is decreased by 2% due to the input reverse polarity protection circuit.
- ⑤ The specified maximum capacitive load for Vo1 and Vo2 output is identical.

Input Specifications

Item	Operating Conditions	Min.	Typ.	Max.	Unit
Input Current (full load / no-load)	Nominal input voltage	-	68/3	70/8	mA
Reflected Ripple Current	Nominal input voltage	-	25	-	
Surge Voltage (1sec. max.)		-0.7	-	180	VDC
Start-up Voltage		-	-	40	
Input Under-voltage Protection		28	33	-	
Start-up Time	Nominal input voltage & constant resistance load	-	10	-	ms
Input Filter		Pi filter			
Hot Plug		Unavailable			

Ctrl *	Module on	Ctrl pin open or pulled high (3.5-12VDC)			
	Module off	Ctrl pin pulled low to GND (0-1.2VDC)			
	Input current when off	-	3	8	mA

Note: *The Ctrl pin voltage is referenced to input GND.

Output Specifications

Item	Operating Conditions		Min.	Typ.	Max.	Unit
Voltage Accuracy ^①	0%-100% load		--	±1	±3	%
Linear Regulation	Input voltage variation from low to high at full load	Vo1	--	±0.2	±0.5	
		Vo2	--	±0.5	±1	
Load Regulation ^②	0%-100% load	ATA1D_YMD-6WR3	--	±0.5	±1	
	5%-100% load	Vo1 of ATA1D_YMD-6WR3	--	±0.5	±1	
		Vo2 of ATA1D_YMD-6WR3	--	±0.5	±1.5	
Cross Regulation	Dual output, Vo1 load at 50%, Vo2 load at range of 25%-100%		--	-	±10	
Transient Recovery Time	25% load step change, nominal input voltage		--	300	500	μs
Transient Response Deviation		5V, ±5V output	--	±3	±8	%
		Others	--	±3	±5	
Temperature Coefficient	Full load		--	±0.02	±0.03	%/°C
Ripple & Noise ^③	20MHz bandwidth, 5%-100% load		--	50	100	mVp-p
Over-voltage Protection	Input voltage range		110	-	160	%Vo
Over-current Protection			120	-	210	%Io
Short-circuit Protection			Continuous, self-recovery			

Note:
 ① Vo2 output voltage accuracy of ±5VDC output converter for 0%-5% load is ±5% max;
 ② ATA1D_YMD-6WR3 load regulation for 0%-100% load is ±5%;
 ③ Under 0% -5% load conditions, ripple & noise does not exceed 5%Vo. The "parallel cable" method is used for Ripple and Noise test, please refer to DC-DC Converter Application Notes for specific information.

General Specifications

Item	Operating Conditions	Min.	Typ.	Max.	Unit
Isolation	Input-output Electric Strength Test for 1 minute with a leakage current of 1mA max.	2250	-	-	VDC
	Input/output-case Electric Strength Test for 1 minute with a leakage current of 1mA max.	1600	-	-	
Insulation Resistance	Input-output resistance at 500VDC	1000	-	-	MΩ
Isolation Capacitance	Input-output capacitance at 100kHz/0.1V	-	1000	-	pF
Operating Temperature	See Fig.1	-40	-	+85	°C
Storage Temperature		-55	-	+125	
Pin Soldering Resistance Temperature	Soldering spot is 1.5mm away from case for 10 seconds	-	-	+300	
Storage Humidity	Non-condensing	5	-	95	%RH
Vibration		IEC61373 - Category 1, Grade B			
Switching Frequency *	PWM Mode	-	300	-	kHz
MTBF	MIL-HDBK-217F@25°C	1000	-	-	k hours

Note: *Switching frequency is measured at full load. The module reduces the switching frequency for light load (below 50%) efficiency improvement.

Mechanical Specifications

Case Material	Aluminum alloy	
Dimensions	Horizontal package(without heat sink)	25.40 × 25.40 × 11.70 mm
	Horizontal package(with heat sink)	25.40 × 25.40 × 16.20 mm
	A2S wiring package (without heat sink)	76.00 × 31.50 × 21.20 mm
	A2S wiring package(with heat sink)	76.00 × 31.50 × 25.20 mm
	A4S rail package(without heat sink)	76.00 × 31.50 × 25.80 mm
	A4S rail package(with heat sink)	76.00 × 31.50 × 29.80 mm

Weight	Without heat sink	Horizontal package/A2S wiring package/A4S rail package	21.0g/36.0g/56.0g (Typ.)
	With heat sink	Horizontal package/A2S wiring package/A4S rail package	26.5g/40.0g/59.0g (Typ.)
Cooling Methods	Free air convection		

EMC Specifications

Emissions	CE	CISPR32/EN55032	CLASS B (see Fig.3 or Fig.4-② for recommended circuit)	
	RE	CISPR32/EN55032	CLASS B (see Fig.3 or Fig.4-② for recommended circuit)	
Immunity	ESD	IEC/EN61000-4-2	Contact $\pm 6\text{kV}$ /Air $\pm 8\text{kV}$	perf. Criteria B
	RS	IEC/EN61000-4-3	20V/m	perf. Criteria A
	EFT	IEC/EN61000-4-4	$\pm 4\text{kV}$ (see Fig.3 or Fig.4-① for recommended circuit)	perf. Criteria B
	Surge	IEC/EN61000-4-5	line to line $\pm 2\text{kV}$ (2Ω , $18\mu\text{F}$ see Fig.3 for recommended circuit) line to ground $\pm 4\text{kV}$ (12Ω , $9\mu\text{F}$ see Fig.3 for recommended circuit)	perf. Criteria B
	CS	IEC/EN61000-4-6	10 Vr.m.s	perf. Criteria A

Typical Characteristic Curves

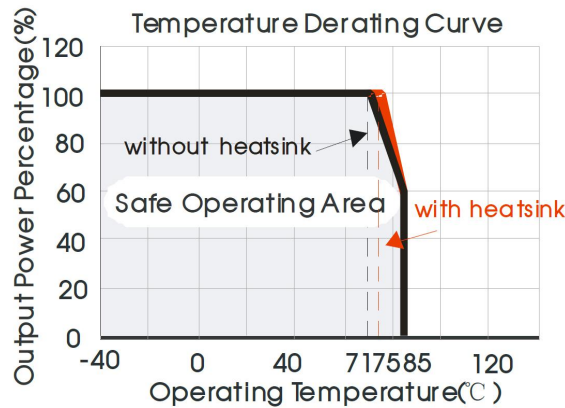
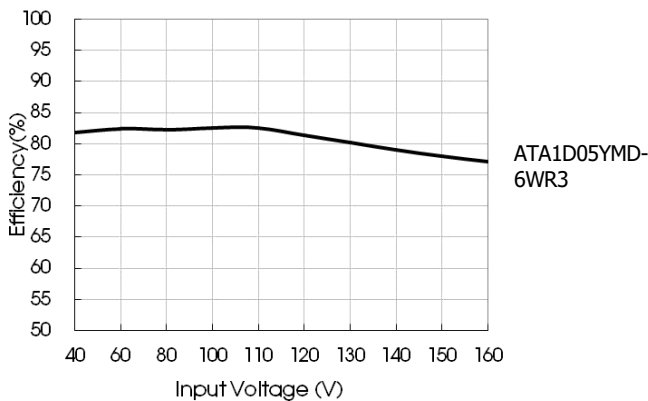
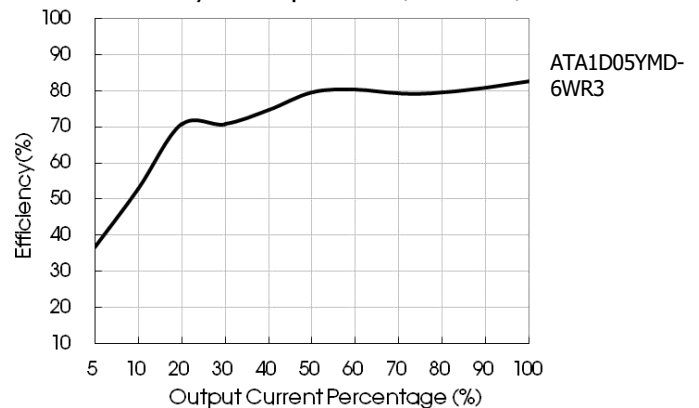

Fig. 1

Efficiency Vs Input Voltage (Full Load)



Efficiency Vs Output Load (Vin=110V)



Efficiency Vs Input Voltage (Full Load)

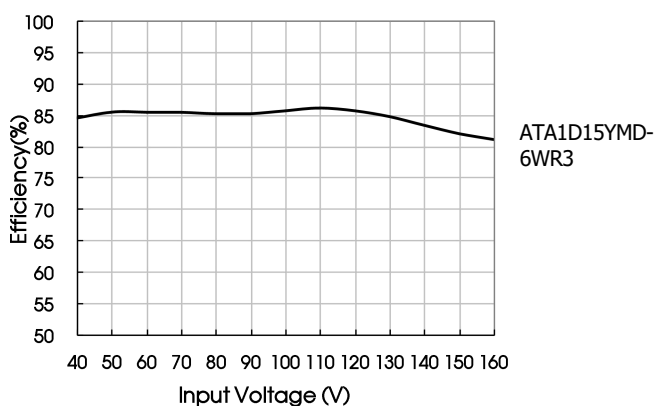

Efficiency Vs Output Load (Vin=110V)

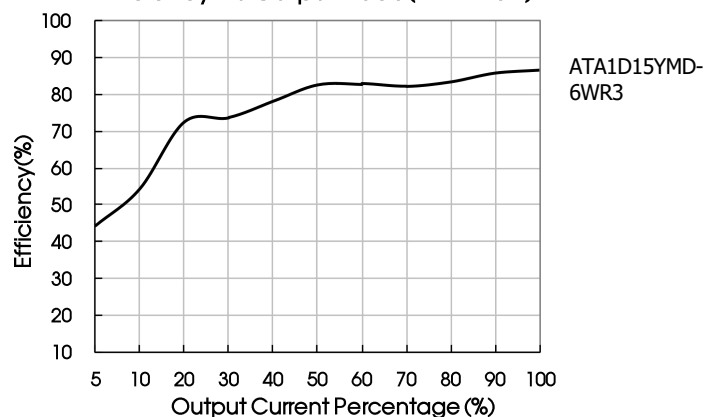

Design Reference

1. Typical application

All the DC/DC converters of this series are tested before delivery using the recommended circuit shown in Fig. 2.

Input and/or output ripple can be further reduced by appropriately increasing the input & output capacitor values C_{in} and C_{out} and/or by selecting capacitors with a low ESR (equivalent series resistance). Also make sure that the capacitance is not exceeding the specified max. capacitive load value of the product.

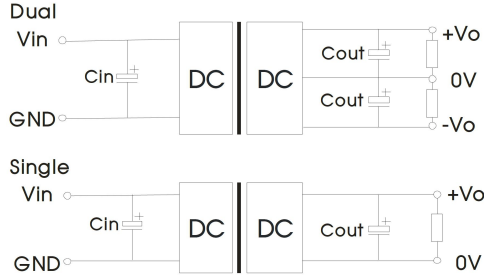

Fig. 2

C_{in}	$V_o(VDC)$	C_{out}
10 μ F/250V -47 μ F/250V	$\pm 5/5$	10 μ F/16V
	$\pm 12/12/\pm 15/15$	10 μ F/25V
	24	10 μ F/50V

2. EMC compliance circuit

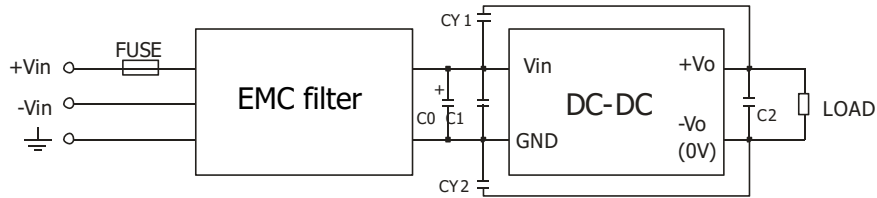

Fig. 3

Fig. 3 Parameter description:

FUSE	Choose according to actual input current
EMC filter	Input voltage range: 40V-160V
C0	100 μ F/200V
C1	Refer to the C_{in} in Fig.2
C2	Refer to the C_{out} in Fig.2
CY1/CY2	1nF/3kV

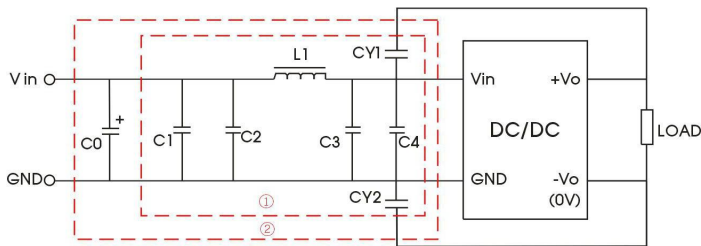

Fig. 4

Fig. 4 Parameter description:

C0	100 μ F/200V
C1/C2/C3/C4	0.22 μ F/250V
L1	68 μ H
CY1/CY2	1nF/3kV

3. The products do not support parallel connection of their output

Horizontal Package (without heat sink) Dimensions and Recommended Layout

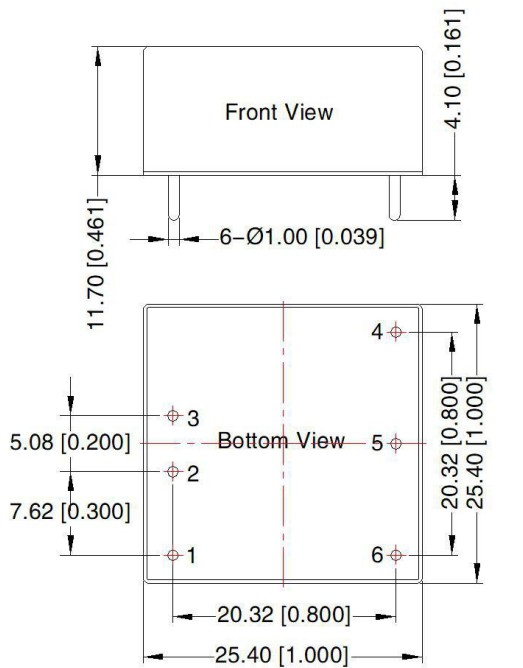

Note:
 Unit: mm[inch]
 Pin diameter tolerances: $\pm 0.10 [\pm 0.004]$
 PIN1/2/3/4/5/6: $\phi 1.0\text{mm}$
 General tolerances: $\pm 0.50 [\pm 0.020]$

THIRD ANGLE PROJECTION

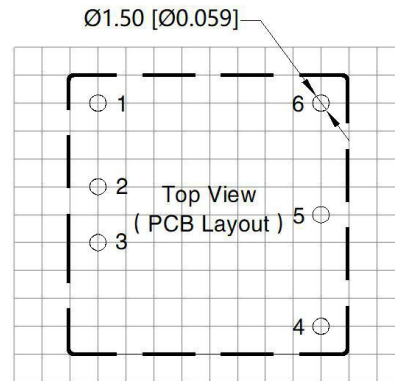

Note: Grid 2.54*2.54mm

Pin	Pin-Out	
	Single	Dual
1	No pin	Ctrl
2	GND	GND
3	Vin	Vin
4	+Vo	+Vo
5	No pin	0V
6	0V	-Vo

Horizontal Package (with heat sink) Dimensions

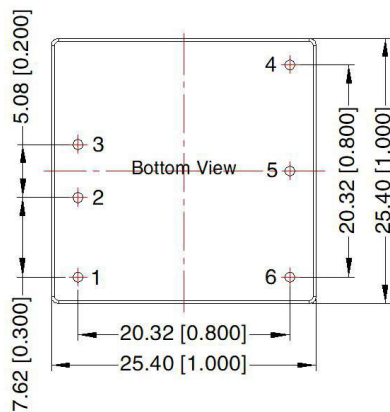
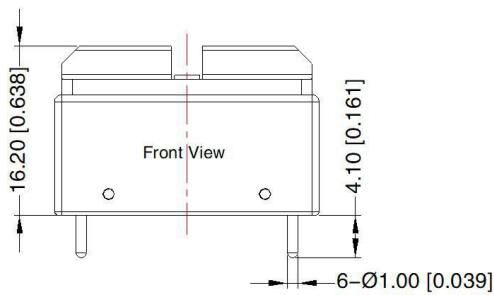

Note:
 Unit: mm[inch]
 Pin diameter tolerances: $\pm 0.10 [\pm 0.004]$
 PIN1/2/3/4/5/6: $\phi 1.0\text{mm}$
 General tolerances: $\pm 0.50 [\pm 0.020]$

THIRD ANGLE PROJECTION

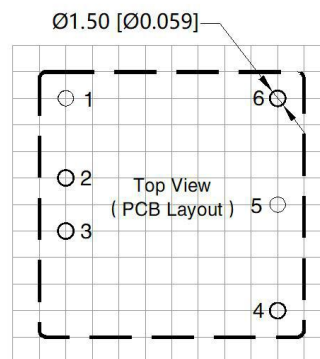

Note: Grid 2.54*2.54mm

Pin	Pin-Out	
	Single	Dual
1	No pin	Ctrl
2	GND	GND
3	Vin	Vin
4	+Vo	+Vo
5	No pin	0V
6	0V	-Vo

ATA1D_YMD-6WR3A2S & ATB1D_YMD-6WR3A2S (without heat sink)
Dimensions

THIRD ANGLE PROJECTION

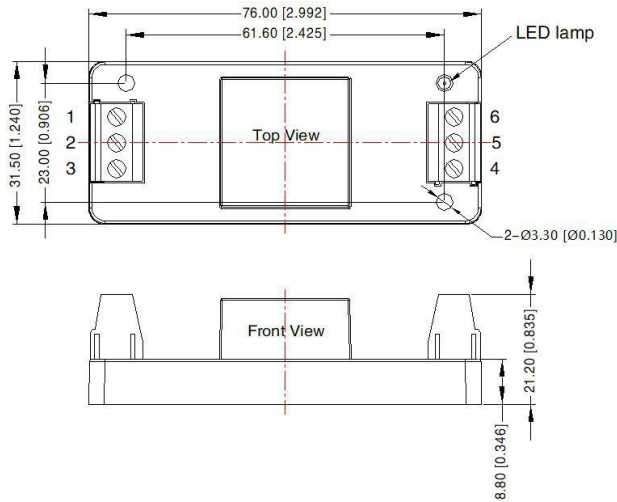

Pin-Out						
Pin	1	2	3	4	5	6
Single	NC	GND	Vin	+Vo	NC	0V
Dual	Ctrl	GND	Vin	+Vo	0V	-Vo

Note:
Unit: mm[inch]
Wire range: 24-12 AWG
Tightening torque: Max 0.4 N·m
General tolerances: ± 0.50 [± 0.020]

ATA1D_YMD-6WHR3A2S & ATB1D_YMD-6WHR3A2S (with heat sink)
Dimensions

THIRD ANGLE PROJECTION

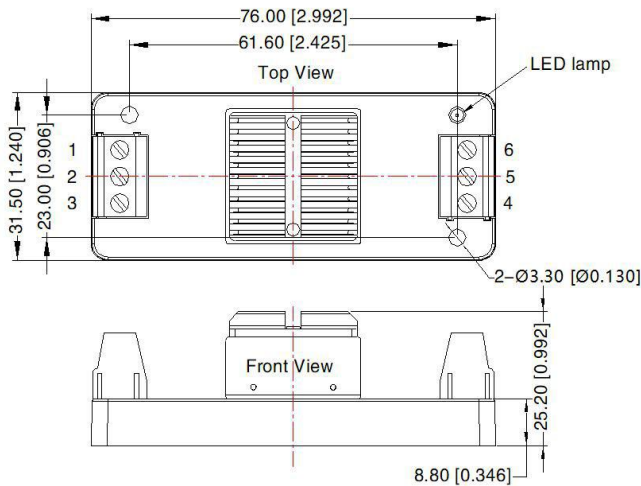

Pin-Out						
Pin	1	2	3	4	5	6
Single	NC	GND	Vin	+Vo	NC	0V
Dual	Ctrl	GND	Vin	+Vo	0V	-Vo

Note:
Unit: mm[inch]
Wire range: 24-12 AWG
Tightening torque: Max 0.4 N·m
General tolerances: ± 1.00 [± 0.039]

ATA1D_YMD-6WR3A4S & ATB1D_YMD-6WR3A4S (without heat sink) Dimensions

THIRD ANGLE PROJECTION 

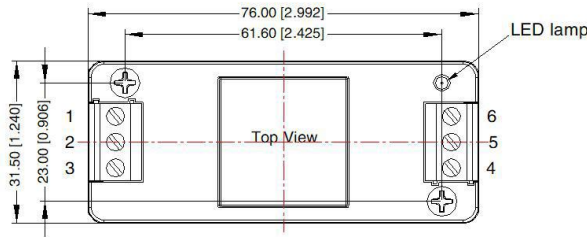

Pin-Out						
Pin	1	2	3	4	5	6
Single	NC	GND	Vin	+Vo	NC	0V
Dual	Ctrl	GND	Vin	+Vo	0V	-Vo

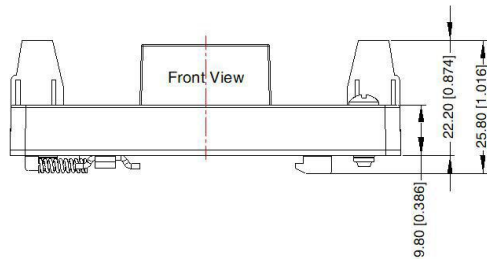

Note:
Unit: mm[inch]
Mounting rail: TS35
Wire range: 24-12 AWG
Tightening torque: Max 0.4 N · m
General tolerances: ± 1.00 [± 0.039]

ATA1D_YMD-6WHR3A4S & ATB1D_YMD-6WHR3A4S (with heat sink) Dimensions

THIRD ANGLE PROJECTION 

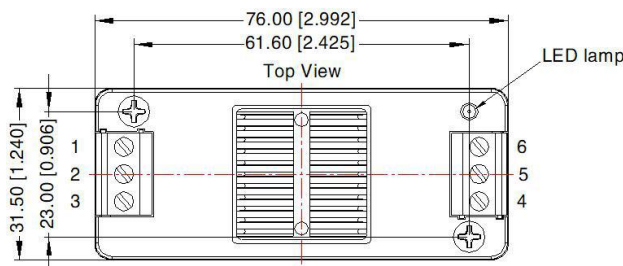

Pin-Out						
Pin	1	2	3	4	5	6
Single	NC	GND	Vin	+Vo	NC	0V
Dual	Ctrl	GND	Vin	+Vo	0V	-Vo

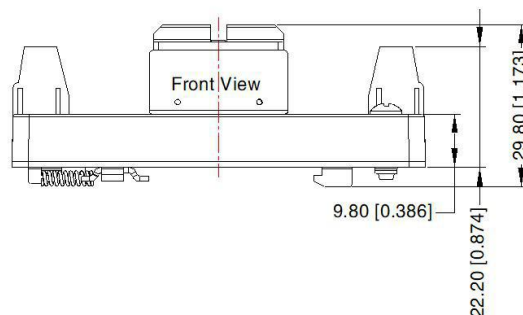

Note:
Unit: mm[inch]
Mounting rail: TS35
Wire range: 24-12 AWG
Tightening torque: Max 0.4 N · m
General tolerances: ± 1.00 [± 0.039]

Note:

1. If the product works under the minimum required load, it cannot guarantee that the performance of the product complies with all the performance indicators in this manual;
2. The maximum capacitive load is tested under the input voltage range and full load condition;
3. Unless otherwise stated, all indexes in this manual are measured at Ta=25°C, humidity <75%RH, nominal input voltage and rated output load;
4. All index testing methods in this manual are based on the enterprise standards of the company;
5. Our company can provide product customization, specific needs can directly contact our technical staff;

GUANGZHOU AMCHARD-POWER TECHNOLOGY CO., LTD.

www.amchard-power.com

Mail:info@amchard-power.com