

FEATURES

1. Ultra-wide 4:1 input voltage range
2. Reinforced I/O isolation test voltage 2.25k VDC
3. Operating ambient temperature range -40°C to +85°C
4. Input under-voltage protection, output short circuit, over-current, over-voltage protection
5. Low output ripple & noise
6. Designed to meet IEC60950/UL60950 safety standards
7. Input Reverse Polarity Protection available with Chassis (A2S) or 35mm DIN-Rail mounting (A4S) version
8. Industry standard pin-out
9. Suitable for electronic equipment and railway vehicle applications using 72V, 96V and 110V battery voltages.



3 years Warranty

Selection Guide

Part No. ^①	Input Voltage (VDC)		Output		Full Load Efficiency ^③ (%) Typ.	Max. Capacitive Load (µF)
	Nominal (Range)	Max. ^②	Voltage (VDC)	Current (mA) Max./Min.		
ATB1D03LD-20WR3	110 (40-160)	170	3.3	5000/0	82	10000
ATB1D05LD-20WR3			5	4000/0	85	10000
ATB1D12LD-20WR3			12	1667/0	86	1600
ATB1D15LD-20WR3			15	1333/0	86	1000
ATB1D24LD-20WR3			24	833/0	87	470

- Note:
- ① Use "H" suffix for heat sink mounting, "A2S" suffix for chassis mounting and "A4S" suffix for DIN-Rail mounting. We recommend to choose modules with a heat sink for enhanced heat dissipation and applications with extreme temperature requirements;
 - ② Absolute maximum stress rating without damage (not recommended);
 - ③ Efficiency is measured at nominal input voltage and rated output load; efficiencies for A2S and A4S Model's is decreased by 2% due to the input reverse polarity protection circuit.

Input Specifications

Item	Operating Conditions	Min.	Typ.	Max.	Unit	
Input Current (full load / no-load)	Nominal input voltage	3.3V output	-	183/10	188/20	mA
		5V output	-	214/10	219/20	
		Others	-	212/3	217/8	
Reflected Ripple Current	Nominal input voltage	-	25	-		
Surge Voltage (1sec. max.)		-0.7	-	180	VDC	
Start-up Voltage	100% load	-	-	40		
Shut-down Voltage		28	33	-		
Start-up Time	Nominal input voltage & constant resistance load	-	10	-	ms	
Input Filter		Pi filter				
Hot Plug		Unavailable				
Ctrl*	Module on	Ctrl pin open or pulled high (3.5-12VDC)				
	Module off	Ctrl pin pulled low to GND (0-1.2VDC)				
	Input current when off	-	2	7	mA	

Note: *The Ctrl pin voltage is referenced to input GND.

Output Specifications

Item	Operating Conditions	Min.	Typ.	Max.	Unit	
Voltage Accuracy	0% -100% load	-	±1	±3	%	
Linear Regulation	Input voltage variation from low to high at full load	-	±0.2	±0.5		
Load Regulation	0% -100% load	-	±0.5	±1		
Transient Recovery Time	25% load step change, nominal input voltage	-	300	500	µs	
Transient Response Deviation		3.3V/5V output	-	±3	±8	%
		Others	-	±3	±5	
Temperature Coefficient	Full load	-	±0.02	±0.03	%/°C	
Ripple & Noise *	20MHz bandwidth, 5% -100% load	-	50	100	mV p-p	
Trim		90	-	110	%Vo	
Over-voltage Protection	Input voltage range	110	-	--		
Over-current Protection		120	-	--		
Short-circuit Protection		Continuous, self-recovery				

Note: *Ripple & Noise at < 5% load is 5%Vo max. The "parallel cable" method is used for Ripple and Noise test, please refer to DC-DC Converter Application Note for specific information.

General Specifications

Item	Operating Conditions	Min.	Typ.	Max.	Unit
Isolation	Input-output Electric Strength Test for 1 minute with a leakage current of 1mA max.	2250	-	-	VDC
	Input/output-case Electric Strength Test for 1 minute with a leakage current of 1mA max.	1600	-	-	
Insulation Resistance	Input-output resistance at 500VDC	1000	-	-	MΩ
Isolation Capacitance	Input-output capacitance at 100KHz/0.1V	-	2200	-	pF
Operating Temperature	See Fig. 1	-40	-	+85	°C
Storage Temperature		-55	-	+125	
Storage Humidity	Non-condensing	5	-	95	%RH
Pin Soldering Resistance Temperature	Soldering spot is 1.5mm away from case for 10 seconds	-	-	300	°C
Switching Frequency*	PWM mode	-	300	-	KHz
Vibration		IEC61373 - Category 1, Grade B			
MTBF	MIL-HDBK-217F@25°C	1000	-	-	K hours

Note: * Switching frequency is measured at full load. The module reduces the switching frequency for light load (below 50%) efficiency improvement.

Mechanical Specifications

Case Material	Aluminum alloy		
Dimensions	Without heat sink	Horizontal package	50.80 × 25.40 × 11.80mm
		A2S chassis mounting	76.00 × 31.50 × 21.20mm
		A4S Din-rail mounting	76.00 × 31.50 × 25.80mm
	With heat sink	Horizontal package	51.40 × 26.20 × 16.50mm
		A2S chassis mounting	76.00 × 31.50 × 25.30mm
		A4S Din-rail mounting	76.00 × 31.50 × 29.90mm
Weight	Without heat sink	Horizontal package/A2S chassis mounting/A4S Din-rail mounting	26.0g/48.0g/68.0g(Typ.)
	With heat sink	Horizontal package/A2S chassis mounting/A4S Din-rail mounting	34.0g/56.0g/76.0g(Typ.)
Cooling Method	Free air convection		

EMC Specifications

Emissions	CE	CISPR32/EN55032	CLASS A (without external components)/CLASS B (see Fig. 3-② for recommended circuit)	
	RE	CISPR32/EN55032	CLASS A (without external components)/CLASS B (see Fig. 3-② for recommended circuit)	
Immunity	ESD	IEC/EN61000-4-2	Contact ±6KV/Air ±8KV perf. Criteria B	
	RS	IEC/EN61000-4-3	10V/m perf. Criteria A	
	EFT	IEC/EN61000-4-4	±4KV (see Fig.3 or Fig.4-① for recommended circuit) perf. Criteria B	
	Surge	IEC/EN61000-4-5	line to line ±2KV (2Ω 0.5uF see Fig.3 for recommended circuit) line to ground ±4KV (12Ω 0.5uF see Fig.3 for recommended circuit)	perf. Criteria B
		EN50121-3-2	line to line ±1KV (42Ω 0.5uF see Fig.4-① for recommended circuit) line to ground ±2KV (42Ω 0.5uF see Fig.4-① for recommended circuit)	perf. Criteria B
	CS	IEC/EN61000-4-6	10 Vr.m.s perf. Criteria A	

Typical Characteristic Curves

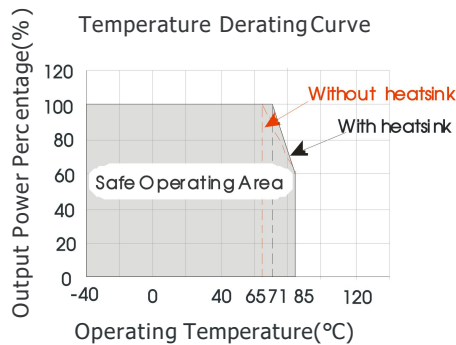

Operating Temperature, Except ATB1D12/15/24LD-20W(H)R3(A2S/A4S)

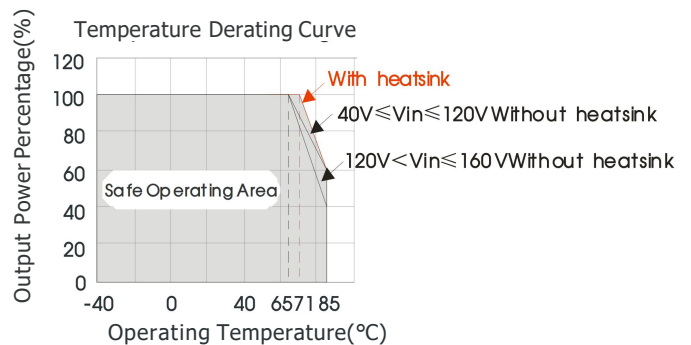

ATB1D03LD-20W(H)R3(A2S/A4S) Operating Temperature

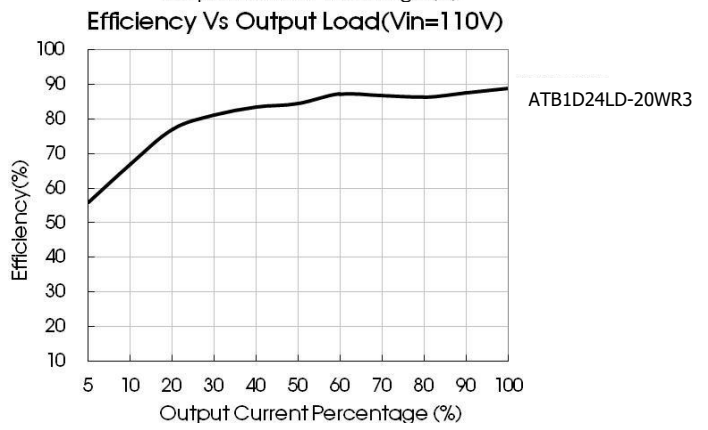
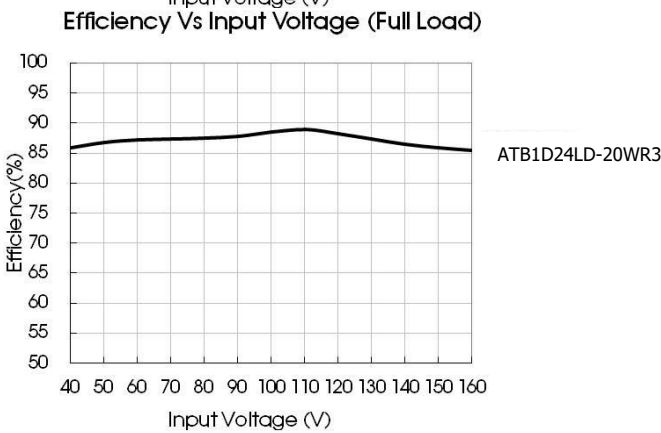
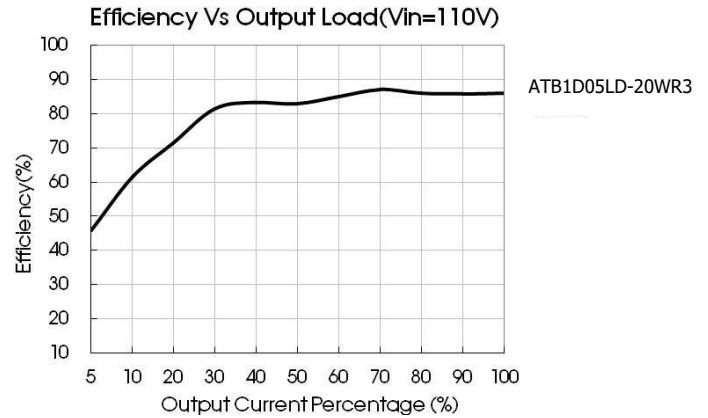
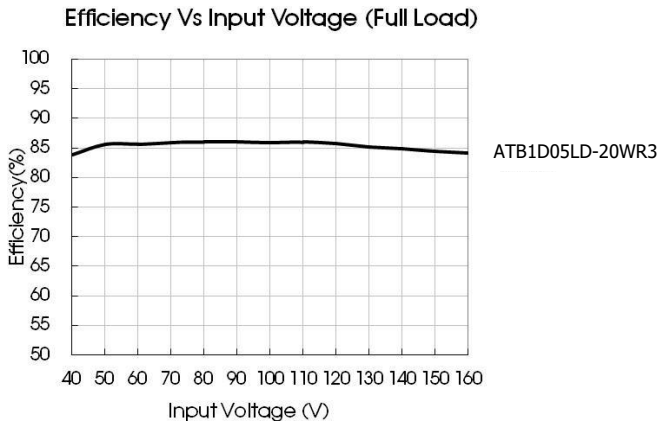

Design Reference

1. Typical application

All DC-DC converters of this series are tested before delivery using the recommended circuit shown in Fig. 2.

Input and/or output ripple can be further reduced by appropriately increasing the input & output capacitor values C_{in} and C_{out} and/or by selecting capacitors with a low ESR (equivalent series resistance). Also make sure that the capacitance is not exceeding the max. capacitive load value of the product.

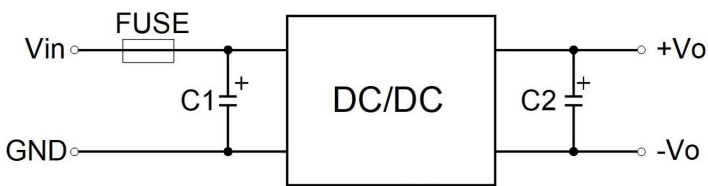

Fig. 2

Vout(VDC)	Fuse	Cin	Cout
3.3/5	2A, slow blow	10 μ F - 47 μ F	470 μ F
12/15			220 μ F
24			100 μ F

2. EMC compliance circuit

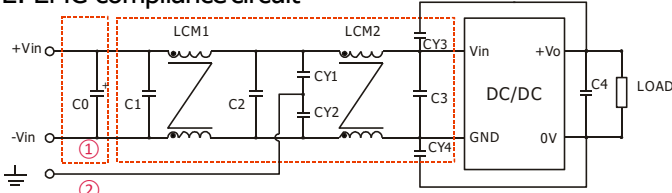

Fig. 4

Notes: Part ① in the Fig. 4 is used for EMS test and part ② for EMI test

Fig.4 List of components:

Output voltage	3.3V	5V	12V	15V	24V
C0	100μF/200V				
C1、C2	0.22μF/250V				
C3	47μF/200V				
LCM1、LCM2	15mH (UU common mode inductance)				
CY1、CY2、CY3、CY4	1000pF/400VAC				
C4	470μF/16V	220μF/25V	100μF/35V		

3. Trim Function for Output Voltage Adjustment (open if unused)

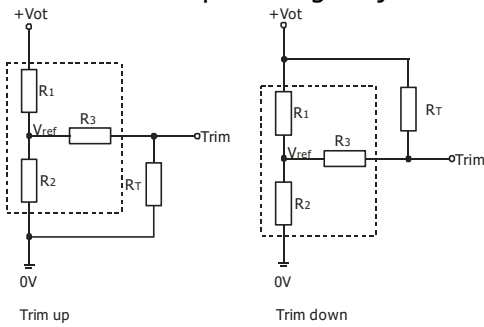

Calculating Trim resistor values:

$$\begin{aligned} \text{up: } R_T &= \frac{aR_2}{R_2-a} - R_3 & a &= \frac{V_{ref}}{V_o' - V_{ref}} \cdot R_1 \\ \text{down: } R_T &= \frac{aR_1}{R_1-a} - R_3 & a &= \frac{V_o' - V_{ref}}{V_{ref}} \cdot R_2 \end{aligned}$$

TRIM resistor connection (dashed line shows internal resistor network)

R_T = Trim Resistor value; a = self-defined parameter; V_o' = desired output voltage

Vout(V)	R1(KΩ)	R2(KΩ)	R3(KΩ)	Vref(V)
3.3	4.801	2.87	10	1.24
5	2.883	2.87	10	2.5
12	11.000	2.87	15	2.5
15	14.384	2.87	15	2.5
24	24.872	2.87	17.8	2.5

4.The products do not support parallel connection of their output

Horizontal Package (without heat sink) Dimensions and Recommended Layout

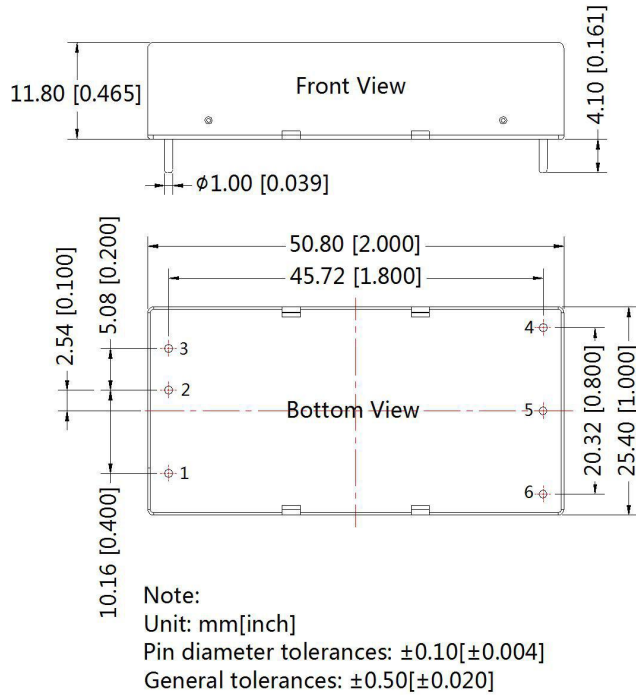

THIRD ANGLE PROJECTION

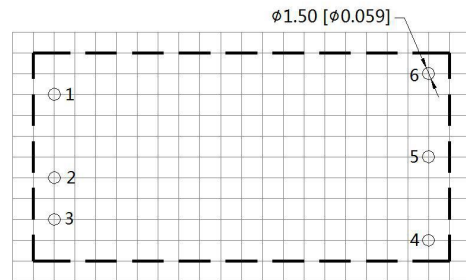

Note : Grid 2.54*2.54mm

Pin-Out	
Pin	Function
1	Ctrl
2	GND
3	Vin
4	+Vo
5	0V
6	Trim

Horizontal Package (with heat sink) Dimensions

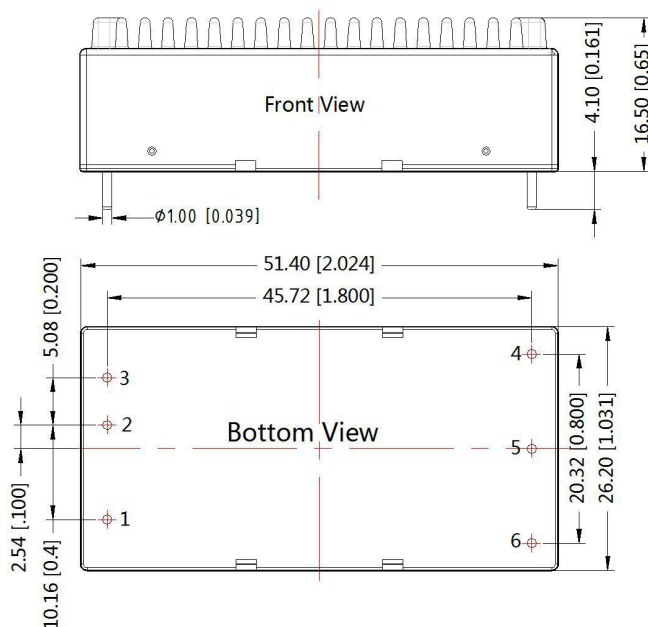

THIRD ANGLE PROJECTION

Pin-Out	
Pin	Function
1	Ctrl
2	GND
3	Vin
4	+Vo
5	0V
6	Trim

Note:
Unit: mm[inch]
General tolerances: $\pm 0.50[\pm 0.020]$

ATB1D LD-20WR3A2S (without heatsink) Dimensions

THIRD ANGLE PROJECTION

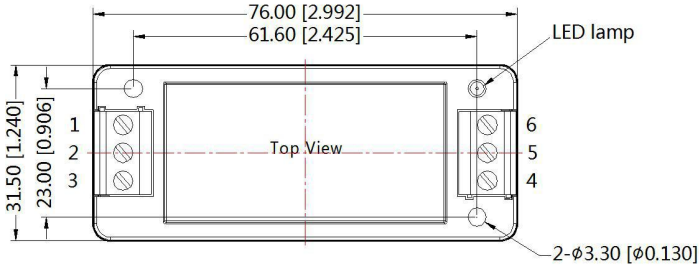

Pin-Out						
Pin	1	2	3	4	5	6
Function	Ctrl	GND	Vin	+Vo	0V	Trim

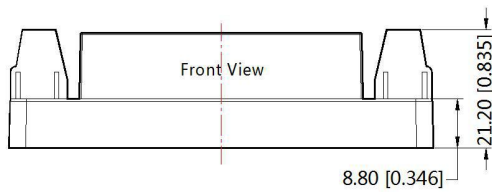

Note:
 Unit: mm[inch]
 Wire range: 24-12 AWG
 Tightening torque: Max 0.4 N·m
 General tolerances: ±0.50[±0.020]

ATB1D LD-20WHR3A2S (with heatsink) Dimensions

THIRD ANGLE PROJECTION

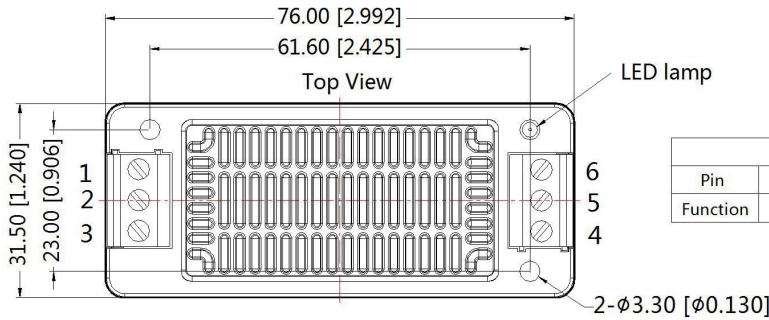

Pin-Out						
Pin	1	2	3	4	5	6
Function	Ctrl	GND	Vin	+Vo	0V	Trim

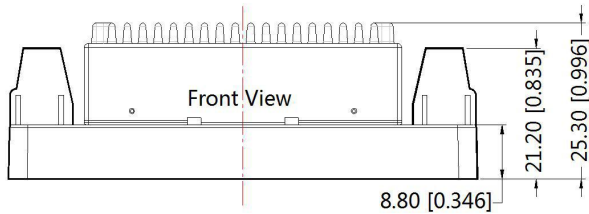

Note:
 Unit: mm[inch]
 Wire range: 24-12 AWG
 Tightening torque: Max 0.4 N·m
 General tolerances: ±1.00[±0.039]

ATB1D LD-20WR3A4S (without heatsink) Dimensions

THIRD ANGLE PROJECTION 

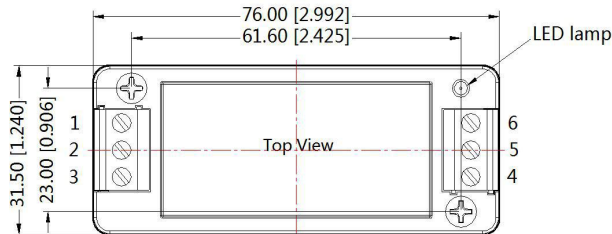

Pin-Out						
Pin	1	2	3	4	5	6
Function	Ctrl	GND	Vin	+Vo	0V	Trim

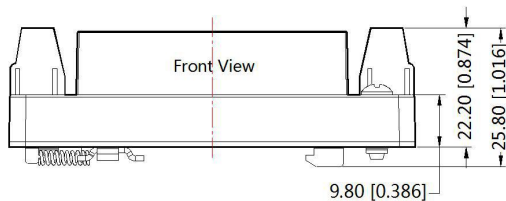

Note:
 Unit: mm[inch]
 Mounting rail: TS35
 Wire range: 24-12 AWG
 Tightening torque: Max 0.4 N·m
 General tolerances: $\pm 1.00[\pm 0.039]$

ATB1D LD-20WHR3A4S (with heatsink) Dimensions

THIRD ANGLE PROJECTION 

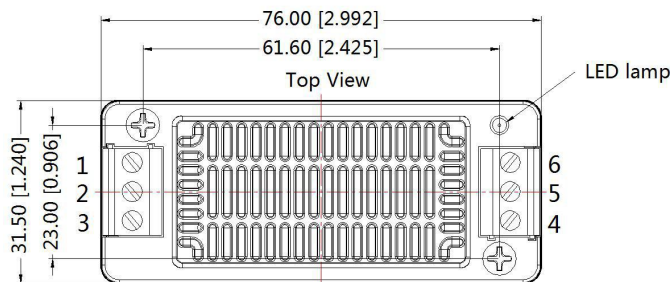

Pin-Out						
Pin	1	2	3	4	5	6
Function	Ctrl	GND	Vin	+Vo	0V	Trim

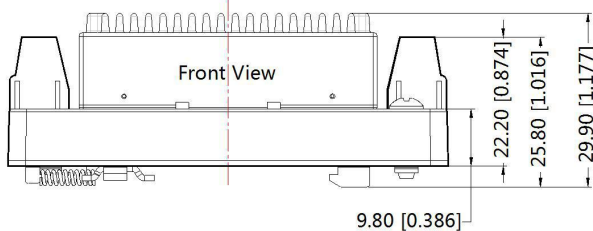

Note:
 Unit: mm[inch]
 Mounting rail: TS35
 Wire range: 24-12 AWG
 Tightening torque: Max 0.4 N·m
 General tolerances: $\pm 1.00[\pm 0.039]$

Note:

1. If the product works under the minimum required load, it cannot guarantee that the performance of the product complies with all the performance indicators in this manual;
2. The maximum capacitive load is tested under the input voltage range and full load condition;
3. Unless otherwise stated, all indexes in this manual are measured at $T_a=25^\circ\text{C}$, humidity $<75\%RH$, nominal input voltage and rated output load;
4. All index testing methods in this manual are based on the enterprise standards of the company;
5. Our company can provide product customization, specific needs can directly contact our technical staff;

GUANGZHOU AMCHARD-POWER TECHNOLOGY CO., LTD.