

FEATURES

1. Ultra-wide 12:1 input voltage range: 14 -160VDC
2. High efficiency up to 86%
3. Reinforced insulation, I/O isolation test voltage 3K VAC
4. Operating ambient temperature range -40°C to +105°C
5. Input under-voltage protection, output over-voltage, over-current, short-circuit protection, over-temperature protection
6. Industry standard package and pin-out
7. Meets EN50155 and AREMA standards
8. Meets IEC62368, UL62368, CSA62368, EN62368 standards
9. Meets EN45545 standards

**3 years
Warranty**

Selection Guide

Part No.	Ctrl Logic ^①	Input Voltage (VDC)		Output		Full Load Efficiency(%) ^③ Min./Typ.	Max. Capacitance Load(μF)
		Typ. (Range)	Max. ^②	Voltage (VDC)	Current (mA) (Max./Min.)		
ATH1D03LD-20W(F/H)R3	P	110 (14-160)	160	3.3	6060/0	82/84	6500
ATH1D05LD-20W(F/H)R3				5	4000/0	82/84	4600
ATH1D12LD-20W(F/H)R3				12	1667/0	84/85	2200
ATH1D15LD-20W(F/H)R3				15	1333/0	84/86	1500
ATH1D24LD-20W(F/H)R3				24	833/0	84/86	460
ATH1D28LD-20W(F/H)R3				28	714/0	84/86	380
ATH1D48LD-20W(F/H)R3				48	417/0	84/86	220
ATH1D54LD-20W(F/H)R3				54	370/0	84/86	220

Note:

- ① "P" means positive logic, "N" means negative logic;
- ② Exceeding the maximum input voltage may cause permanent damage;
- ③ This efficiency value is the full load efficiency measured at the nomina 48V input voltage at room temperature;
- ④ When the product with input at 14V~16.8V / 160V-200V, the working time is 0.1s and 1s respectively;
- ⑤ When starting with a capacitive load, Trim is only applicable to the input voltage range 16.8V-160V.

Input Specifications

Item	Operating Conditions		Min.	Typ.	Max.	Unit
Input Current (full load)	24V input	3.3V, 5V, 12V, 15V Output	-	969	1017	mA
		24V, 28V, 48V, 54V Output	-	969	993	
	36V input	3.3V, 5V, 12V, 15V Output	-	646	678	
		24V, 28V, 48V, 54V Output	-	646	662	
	48V input	3.3V, 5V, 12V, 15V Output	-	485	509	
		24V, 28V, 48V, 54V Output	-	485	497	
Input Current (full load)	72V input	3.3V, 5V, 12V, 15V Output	-	323	339	
		24V, 28V, 48V, 54V Output	-	323	331	

	96V input	3.3V, 5V, 12V, 15V Output	-	243	255	
		24V, 28V, 48V, 54V Output	-	243	249	
	110V input	3.3V, 5V, 12V, 15V Output	-	212	222	
		24V, 28V, 48V, 54V Output	-	212	217	
Reflected Ripple Current	Nominal input voltage		-	150	190	VDC
Surge Voltage (1sec. max.)			-0.7	-	200	
Start-up Voltage			-	-	14	
Start-up Time			-	50	100	ms
No-load input power	Ctrl pin open or pulled high, DC-DC ON (14-160VDC)		-	1.2	2.2	W
Idle input power	Ctrl pin pulled low to GND, DC-DC OFF (14-160VDC)		-	0.7	1.6	
Ctrl ^①	Module on		Ctrl pin open or pulled high (3.5-12VDC)			
	Module off		Ctrl pin pulled low to -Vin (0-1.2VDC)			
Input Under-voltage rotection			10	12	-	VDC
Note:						
①The Ctrl pin voltage is referenced to input GND.						

Output Specifications

Item	Operating Conditions		Min.	Typ.	Max.	Unit
Voltage Accuracy	Nominal input voltage, 5%-100% load	3.3V, 5V output	-	±1	±3	%
		Other output				
Linear Regulation	Input voltage variation from low to high at full load		-	±0.2	±0.5	
Load Regulation	Nominal input voltage, 5%-100% load		-	±0.5	±1	
Transient Recovery Time			-	300	500	μs
Transient Response Deviation	25% load step change @25°C	3.3V, 5V output	-	±4	±9	%
		Other output	-	±3	±5	
Temperature Coefficient	Nominal input voltage, full load		-	-	±0.03	%/°C
Ripple & Noise ^①	20MHz bandwidth, 5%-100%load	3.3V, 5V, 12V, 15V output	-	100	150	mVp-p
		Other output	-	150	200	
Trim			90	-	110	%Vo
Over-temperature Protection	Max. Case Temperature		105	-	130	°C
Over-voltage Protection	Input voltage range		110	-	-	%Vo
Over-current Protection			110	-	260	%Io
Short-circuit Protection			Hiccup, continuous, self-recovery			
Note:						
①The "Tip and barrel method" is used for ripple and noise test, for details please refer to Fig.1.						

General Specifications

Item	Operating Conditions		Min.	Typ.	Max.	Unit
Isolation	Electric Strength Test for 1 minute with a leakage current of 5mA max	Input-output	3000	-	-	VAC
		Input-case	2800	-	-	
		Output-case	2100	-	-	
Insulation Resistance	Input-output resistance at 500VDC		1000	-	-	MΩ
Isolation Capacitance	Input-output capacitance at 100KHz/0.1V		-	1500	-	pF
Operating Temperature			-40	-	105	°C
Storage Temperature			-55	-	125	
Pin Soldering Resistance Temperature	Soldering spot is 1.5mm away from case for 10 seconds		-	-	300	
Storage Humidity	Non-condensing		5	-	95	%RH
Switching Frequency	PWM mode		-	170	-	kHz
MTBF	IEC 61709 @25°C		1000	-	-	k hours
Cooling Test			EN60068-2-1			
Dry Heat			EN60068-2-2			
Damp Heat			EN60068-2-30			

Shock and Vibration Test		IEC/EN61373 Class B
Pollution level		PD 3
Fire & smoke compliance		EN45545-2, HL3
Salt mist test		EN60068-2-11, Ka
Altitude ^①		Altitude: ≤5000m, Atmospheric pressure: 50~110KPa

Note:

① If the product is used at an altitude above 2000m, it is necessary to ensure that the surface temperature of the product is lower than 130°C.

Mechanical Specifications

Case Material	Aluminum alloy case; Black plastic bottom, flame-retardant and heat-resistant (UL94 V-0)	
Dimension	Without heat sink	50.80 x 25.40 x 11.80 mm
	With H heat sink	50.80 x 25.40 x 22.80 mm
	With F heat sink	50.80 x 40 x 11.80 mm
Weight	Without heat sink	41.5g (Typ.)
	With H heat sink	55.0g (Typ.)
	With F heat sink	43.0g (Typ.)
Cooling Method	Conduction cooling or forced air cooling Free air convection cooling with additional heat sink	

Electromagnetic Compatibility (EN50121-3-2)

Emissions	CE	EN50121-3-2	150kHz-500kHz	99dBuV	(see Fig. 4 for recommended circuit)	
			500kHz-30MHz	93dBuV	(see Fig. 4 for recommended circuit)	
		EN55032	150kHz-500kHz	79dBuV	(see Fig. 4 for recommended circuit)	
			500kHz-30MHz	73dBuV	(see Fig. 4 for recommended circuit)	
	RE	CISPR16-2-3	30MHz-230MHz	40dBuV/m at 10m	(see Fig. 4 for recommended circuit)	
			230MHz-1GHz	47dBuV/m at 10m	(see Fig. 4 for recommended circuit)	
1GHz-6GHz			47dBuV/m at 10m	(see Fig. 4 for recommended circuit)		
Immunity	ESD	EN61000-4-2	Contact ±6kV/Air ±8kV			perf. Criteria A
	RS	EN61000-4-3	80 – 800MHz	20V/m	(see Fig. 4 for recommended circuit)	perf. Criteria A
			800 – 1000MHz	20V/m	(see Fig. 4 for recommended circuit)	
			1400 – 2000MHz	10V/m	(see Fig. 4 for recommended circuit)	
			2000 – 2700MHz	5V/m	(see Fig. 4 for recommended circuit)	
			5100 – 6000MHz	3V/m	(see Fig. 4 for recommended circuit)	
	EFT	EN61000-4-4	±2kV	5/50ns	5kHz	(see Fig. 4 for recommended circuit)
Surge	EN61000-4-5	line to line ±1kV (42Ω, 0.5μF) (see Fig. 4 for recommended circuit)				perf. Criteria A
		line to line ±1kV (2Ω, 18μF) (see Fig. 4 for recommended circuit)				
CS	EN61000-4-6	0.15MHz-80MHz	10V r.m.s	(see Fig. 4 for recommended circuit)		perf. Criteria A

Electromagnetic Compatibility (EMC) (AREMA)

Emissions	CE	CISPR16-2-1	150kHz-500kHz	79dBuV	(see Fig. 4 for recommended circuit)	
		CISPR16-1-2	500kHz-30MHz	73dBuV	(see Fig. 4 for recommended circuit)	
	RE	CISPR16-2-3	30MHz-230MHz	40dBuV/m at 10m	(see Fig. 4 for recommended circuit)	
	230MHz-1GHz		47dBuV/m at 10m	(see Fig. 4 for recommended circuit)		
Immunity	ESD	IEC61000-4-2	Contact ±6kV/Air ±8kV			perf. Criteria A
	RS	IEC61000-4-3	80 – 1000MHz	10V/m	(see Fig. 4 for recommended circuit)	perf. Criteria A
			160 – 165MHz	20V/m	(see Fig. 4 for recommended circuit)	
			450 – 470MHz	20V/m	(see Fig. 4 for recommended circuit)	
			800 – 960MHz	20V/m	(see Fig. 4 for recommended circuit)	
		1400 – 2000MHz	20V/m	(see Fig. 4 for recommended circuit)		

			2100 – 2500MHz	5V/m	(see Fig. 4 for recommended circuit)	
EFT	IEC61000-4-4	$\pm 2kV$	5/50ns	5kHz	(see Fig. 4 for recommended circuit)	perf. Criteria A
Surge	IEC61000-4-5	line to line $\pm 2kV$ (2 Ω , 18 μF)			(see Fig. 4 for recommended circuit)	perf. Criteria A
CS	IEC61000-4-6	0.15MHz-80MHz	10V r.m.s		(see Fig. 4 for recommended circuit)	perf. Criteria A

Typical Performance Curves

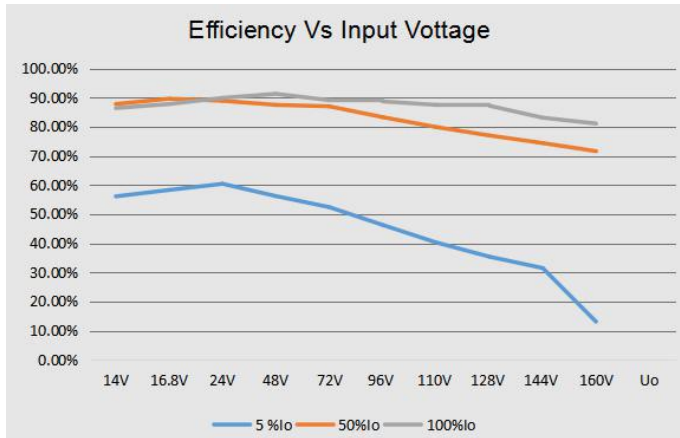

ATH1D54LD-20WR3 Efficiency curve of input voltage
(normal temperature)

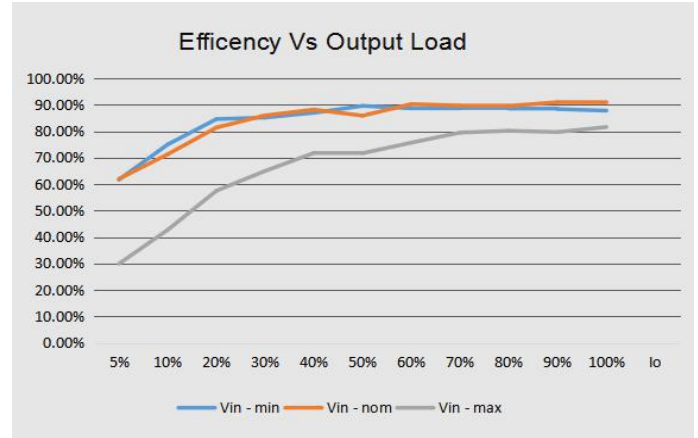

ATH1D54LD-20WR3 Efficiency curve of output load
(normal temperature)

ATH1D03/05/12LD-20W(H/F)R3 temperature derating curve
(Vin=110V, Without wind)

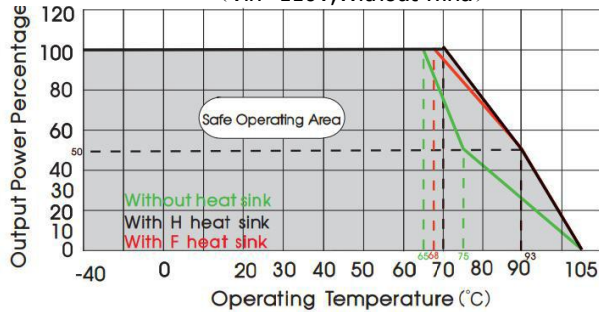

ATH1D24/48/54LD-20W(H/F)R3 temperature derating curve
(Vin=110V, Without wind)

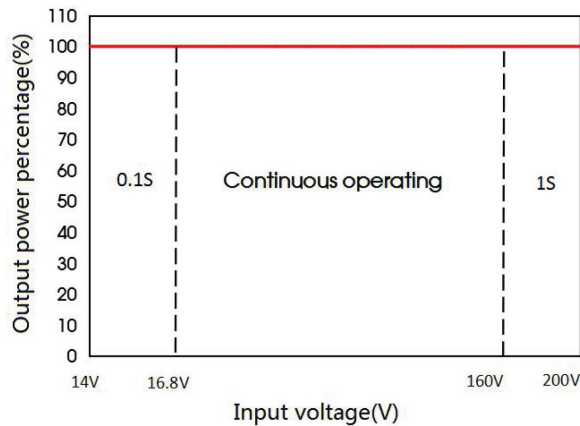
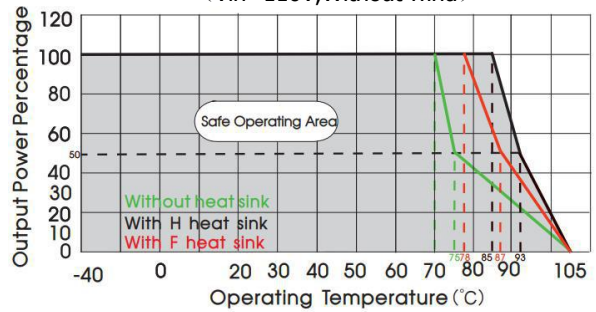

Design Reference

1. Ripple & noise

All the DC-DC converters of this series are tested before delivery using the recommended circuit shown in Fig. 1.

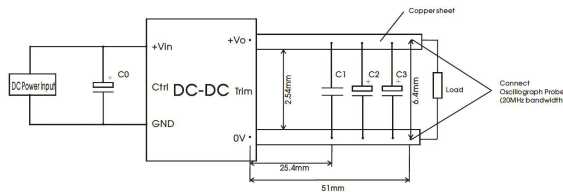

Fig.1

Capacitors Output Voltage Value	C0(μF)	C1(μF)	C2(μF)	C3(μF)
3.3V/5VDC	100μF /250V	1μF/10V	10μF/50V	680μF/16V
12VDC		1μF/16V		330μF/25V
15VDC		1μF/25V		
24VDC		1μF/50V	100μF/50V	
28VDC				
48VDC		1μF/100V	10μF/63V	82μF/63V
54VDC		1μF/100V		

2. Typical application

- (1) We recommended using EMC circuit, otherwise please ensure that at least a 100μF electrolytic capacitors is connected at the input in order to ensure adequate voltage surge suppression and protection.
- (2) Output ripple can be further reduced by appropriately increasing the output capacitor values Cin, Cout and/or by selecting capacitors with a low ESR (equivalent series resistance). Also make sure that the capacitance is not exceeding the specified max. capacitance load value of the product.
- (3) The recommended circuit for Ctrl function please refer to Fig.2.

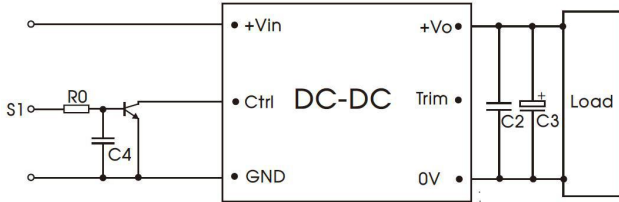

Fig.2

Components	Value	Recommended Component
R0	10K	-
C4	0.1μF	Voltage ≥ 25V
Q1	Ic ≥ 10mA	Voltage ≥ 30V

3. Trim function for output voltage adjustment (open if unused)

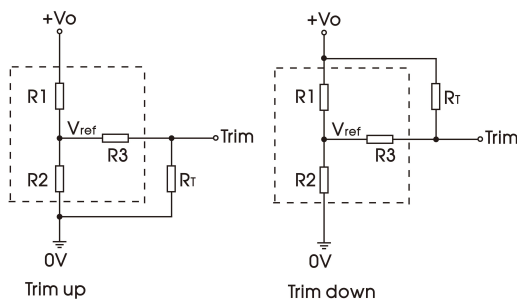

Fig3

Calculation formula of Trim resistance:

$$\text{Trim up : } R_T = \frac{a * R_2}{R_2 - a} - R_3 \quad a = \frac{V_{ref} * R_1}{V_o - V_{ref}}$$

$$\text{Trim down : } R_T = \frac{b * R_1}{R_1 - b} - R_3 \quad b = \frac{(V_o - V_{ref}) * R_2}{V_{ref}}$$

Note:

Table 1 Values of R1, R2, R3, Vref; RT[kΩ]: Resistance of Trim;
a, : self-defined parameter, accurate to two decimal places;
Vo: Output voltage change;

Trim resistor connection (dashed line shows internal resistor network)

Table 1

Res	Vo	3.3(VDC)	5(VDC)	12(VDC)	15(VDC)	24(VDC)	28(VDC)	48(VDC)	54(VDC)
R1(KΩ)		3.974	9.09	11.57	15.12	16.08	24	46.79	59.73
R2(KΩ)		2.4	3	3	3	5	5	3.75	3.75
R3(KΩ)		4	4	12.4	12.4	18.2	20	20	11.2
Vref(V)		1.24	1.24	2.5	2.5	2.5	2.5	2.5	2.5

Practical Example trim up +10% for 12V output:

$$a = \frac{2.5 * 11.57}{13.2 - 2.5} = 2.7$$

$$R_T = \frac{2.7 * 3}{3 - 2.7} - 4 = 27K\Omega$$

R_T according to E24 ≈ 27k Ω

Practical Example trim down -10% for 12V output:

$$b = \frac{(10.8 - 2.5) * 3}{2.5} = 9.96$$

$$R_T = \frac{9.96 * 11.57}{11.57 - 9.96} - 12.4 = 59.18K\Omega$$

R_T according to E24 ≈ 62k Ω

4. EMC compliance circuit

EMC recommended circuit and parameters when the shell is not connected

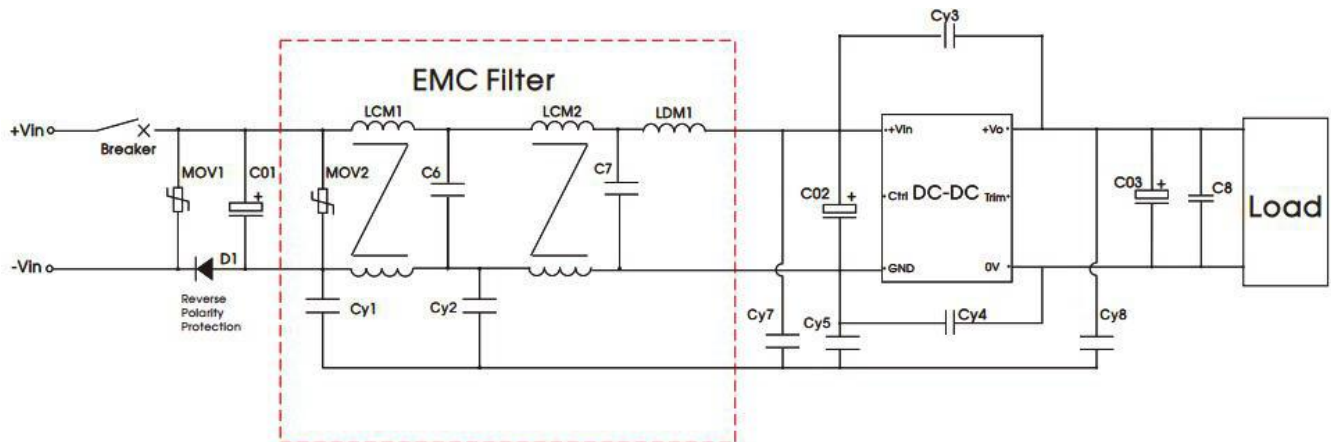

Fig.4

Components Value	CY3	CY4	CY5	CY7, CY8	MOV1	D1
Matching Power Output Voltage						
3.3V						
5V						
12V						
15V						
24V	2200 pF /400VAC	4700 pF /400VAC	2200 pF /400VAC	1000 pF /400VAC	10D221K	16A Withstand voltage ≥600V
28V						
48V						
54V						

Breaker

The Breaker value varies with different power modules and must be selected in accordance with the specified input current of the corresponding power converter, but not exceeding the filter specifications.

Note: A ferrite core on the power lines and load lines can ensure a better EMI test margin.

EMC Filter		
Component	Value	Recommended Component
C6, C7	0.1μF	Voltage≥250V
LCM1, LCM2	1.2mH	FT-ABX1D CM inductor
LDM1	4.7μH	PH-3152LF DM inductor
CY1, CY2	1000 pF /400VAC	Y1 safety capacitor
MOV1	TVR10221KSERW	Varistor
MOV2	7D221K	Varistor

Note: EMC filter recommended 2.5A(MAX).

Surge Standard	Components	Value	Recommended Component
line to line ±1kV (42Ω, 0.5μF) line to line ±1kV (2Ω, 18μF)	C01	220μF	Voltage≥200V
	C02	220μF	Voltage≥200V
line to line ±2kV (2Ω, 18μF)	C01	330μF	Voltage≥200V
	C02	220μF	Voltage≥200V

Note : Reducing C01\C02 will affect the EMI margin, please select the reference value according to the actual situation.

5. Recommended capacitance for holding time

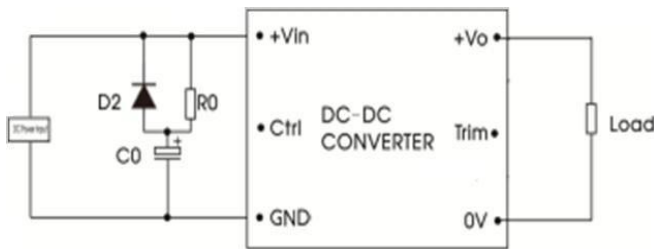

Fig.5

Recommended formula for calculating capacitance:

$$C_0 = \frac{2P_o \Delta t}{(V_{input}^2 - V_{shutdown}^2) \cdot \eta} \times 10^3$$

Remark:

PO(W): Output power;

η: Efficiency;

Δt(ms): Power-down retention time

10ms power off holding time reference table:

Vin (V)	24	36	48	72	96	110	
Po (W)	20	20	20	20	20	20	
Turn-off voltage (V)	14	14	14	14	14	14	
D2	10A/250V						
R0	200Ω/10W						
C0 (μF)	Δt: 10ms	2400	730	400	180	100	82
Vco		35V	50V	63V	100V	150V	150V

ATH1D_LD-20WR3 Dimensions and Recommended Layout

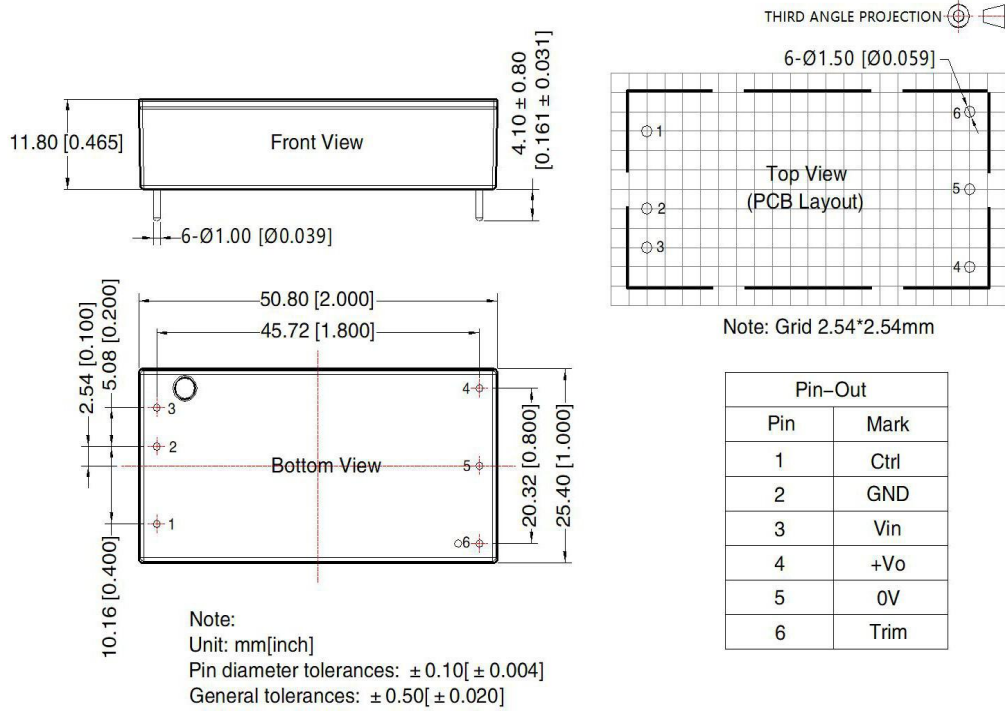

ATH1D_LD-20WFR3 Dimensions and Recommended Layout

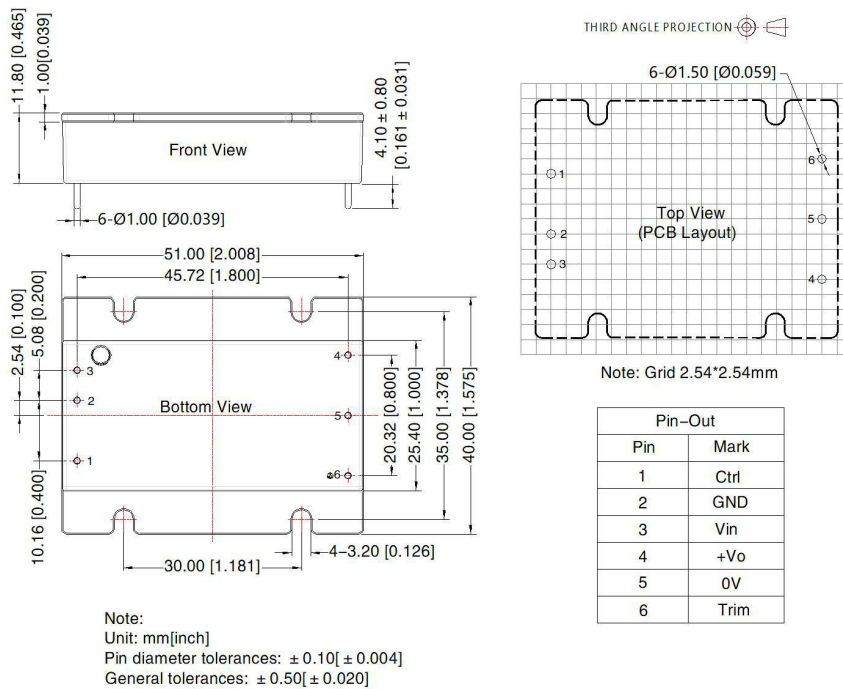

ATH1D_LD-20WHR3 Dimensions and Recommended Layout

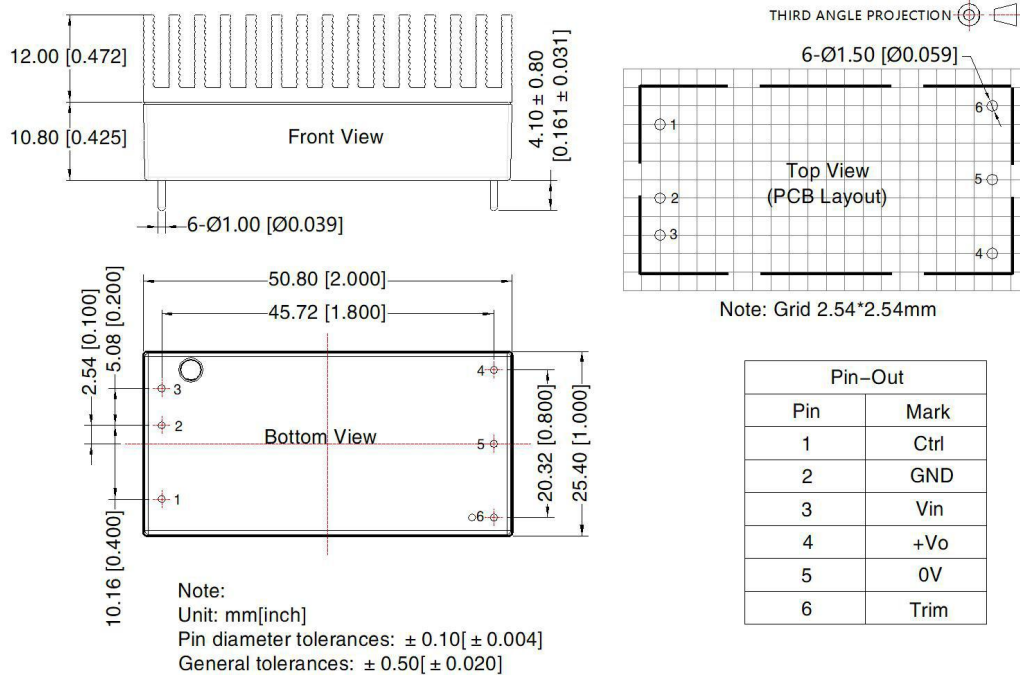

Note:

1. If the product works under the minimum required load, it cannot guarantee that the performance of the product complies with all the performance indicators in this manual;
2. The maximum capacitive load is tested under the input voltage range and full load condition;
3. Unless otherwise stated, all indexes in this manual are measured at Ta=25°C, humidity <75%RH, nominal input voltage and rated output load;
4. All index testing methods in this manual are based on the enterprise standards of the company;
5. Our company can provide product customization, specific needs can directly contact our technical staff;