

Product Feature

1. Package Type: 2"X 1"
2. Operating temperature range: -40°C - +85°C
3. High efficiency up to 90%
4. Isolation voltage: 1500VDC
5. The mechanism has input undervoltage protection, output short circuit protection and over current protection
6. 2:1 Ultra-wide input voltage range
7. Fields of application: Power, industrial control, communications, Internet of Things, automotive, etc



3 years Warranty

Selection Guide

Part No.	Input Voltage (VDC)		Output		Full Load Efficiency% (Typ.)	Capacitive Load(μF) Max.
	Nominal (Range)	Maximum	Voltage (VDC)	Current (mA)		
GTB2403LD-30WR3	24 (18-36)	40	3.3	6000	85	10000
GTB2405LD-30WR3			5	6000	88	10000
GTB2412LD-30WR3			12	2500	88	2700
GTB2415LD-30WR3			15	2000	90	1680
GTB2424LD-30WR3			24	1250	90	680
GTA2412LD-30WR3			±12	±1250	90	#1250
GTA2415LD-30WR3			±15	±1000	90	#680
GTB4803LD-30WR3	48 (36-75)	80	3.3	6000/0	86	10000
GTB4805LD-30WR3			5	6000/0	88	10000
GTB4812LD-30WR3			12	2500/0	88	2700
GTB4815LD-30WR3			15	2000/0	89	1680
GTB4824LD-30WR3			24	1250/0	89	680

each output

Input Specifications

Item	Operating Conditions		Min.	Typ.	Max.	Unit
Input Current(full load/no-load)	24VDC nominal input series	3.3VDC	--	976/60	993/100	mA
		5VDC output	--	1454/60	1488/100	
		Other	--	1388/6	1488/16	
	48VDC nominal input series	3.3VDC	--	474/20	485/30	
		5VDC output	--	710/20	726/35	
		Other	--	702/5	744/10	
Reflected Ripple Current	nominal input series		--	40	--	

Impulse Voltage	24VDC nominal input series	-0.7	--	50	VDC
	48VDC nominal input series	-0.7	--	100	
Starting Voltage	24VDC nominal input series	--	--	18	
	48VDC nominal input series	--	--	36	
Ctrl	turn off module	connected GND or (0-1.2V)			
	turn on module	No connected or (3.5-12V)			
	Input current when off	--	5	8	mA
Input Filter	PI filter				

Output Specifications

Item	Operating Conditions	Min.	Typ.	Max.	Unit	
Output Voltage Accuracy	5%-100% load	--	±1.0	±3.0	%	
	0%-5% load	--	±1.0	±5.0		
Linear Regulation	Vin=Min. to Max. @Full Load	--	±0.2	±0.5		
Load Regulation	5%-100% load	--	±0.5	±1.0		
Ripple & Noise	20MHz bandwidth,5%-100% load	--	50	100	mVp-p	
Transient Recovery Time	25% Load Step Change, nominal input voltage	--	300	500	μs	
Transient Response Deviation	25% Load Step Change, nominal input	3.3/5VDC	--	±5	±8	%
		Other	--	±3	±5	
Temperature Coefficient	Full Load	--	--	±0.03	%/°C	
Trim	input voltage range	--	±10.0	--	%	
Over Voltage Protection		110	--	190	%	
Over Current Protection		110	--	160	%	
Short-Circuit Protection		Continuous, Self-Recovery				

General Specifications

Item	Operating Conditions	Min.	Typ.	Max.	Unit
Isolation Voltage	Input-output, test time 1 minute, leakage current less than 1mA	1500	--	--	VDC
Insulation Resistance	Input-output, insulated voltage 500VDC	1000	--	--	MΩ
Isolation Capacitance	Input-output, 100KHz/0.1V	--	2000	--	pF
Operating Temperature	See Fig 1	-40	--	+80	°C
Storage Temperature		-50	--	+125	
Storage Humidity	Non-condensing	--	--	95	%RH
Soldering Profile	1.5mm from case for 10 sec	--	--	300	°C
Switching Frequency	Full load, nominal input voltage	--	300	--	kHz
MTBF	MIL-HDBK-217F@25°C	1000	--	--	K Hours

Mechanical Specifications

Case Material	Aluminum alloy
Package Dimensions	25.4mm * 25.40mm * 11.80 mm
Weight	28.00g(Typ.)
Cooling Method	Free air convection

EMC Specifications

EMI	CE	EN55032, FCC part 15	CLASS B
	RE		
EMS	ESD	EN61000-4-2 Air \pm 8kV , Contact \pm 6kV	perf. Criteria B
	RS	EN61000-4-3 10V/m	perf. Criteria A
	EFT	EN61000-4-4 \pm 2kV	perf. Criteria B
	Surge	EN61000-4-5 \pm 1kV	perf. Criteria B
	CS	EN61000-4-6 3Vrms	perf. Criteria A

Typical Characteristic Curves

Temperature Derating (GTB2403/05LD-30WR3)

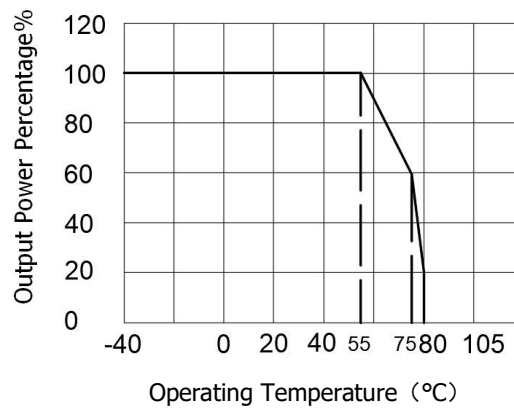
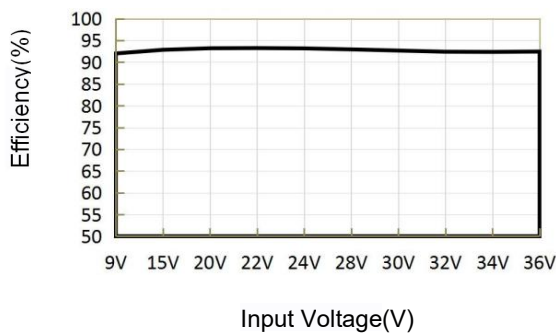
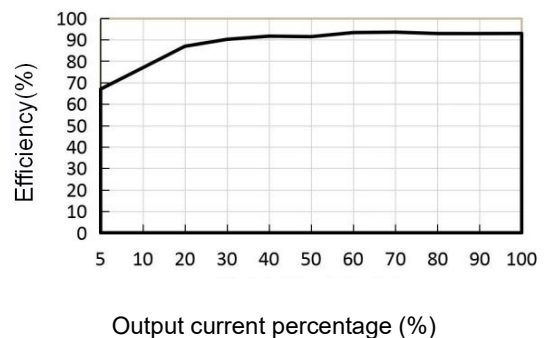

Fig 1

Efficiency VS input voltage (full load) (2405LD)



Efficiency VS out Power (2405LD)



Typical Circuit Design And Application

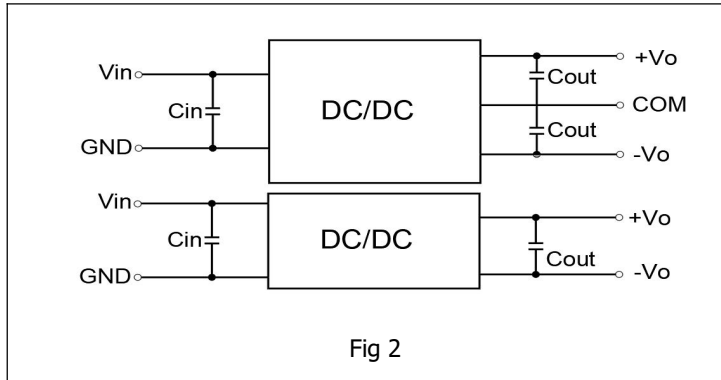

Fig 2

recommended component parameters		
Vout(VDC)	Cout (μF)	Cin(μF)
3.3/5	470	100
12/15/24	100	

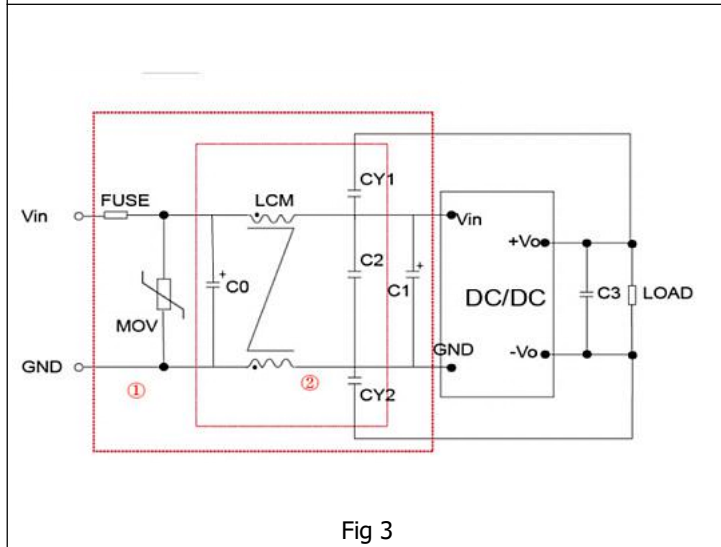
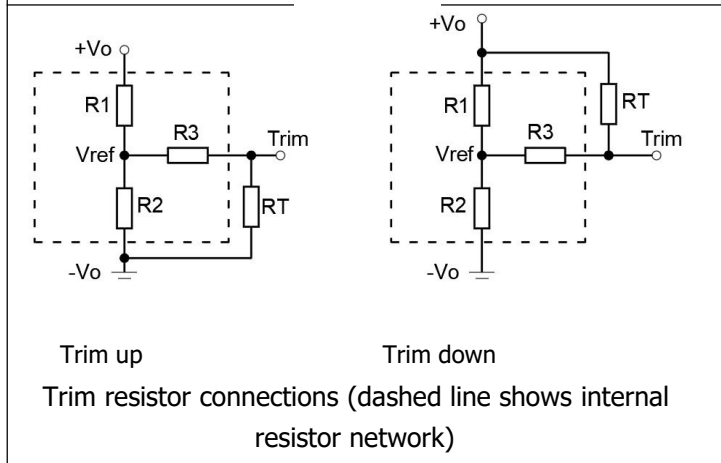

Fig 3

EMI recommended component parameters		
Model	Vin: 24VDC	Vin: 48VDC
FUSE	Select according to the actual input current of the customer	
MOV	20D470K	14D101K
C0	680μF/50V	330μF/100V
C1	330μF/50V	330μF/100V
C2	4.7μF/50V	2.2μF/100V
C3	Refer to the Cout parameter in Figure 2	
LCM	1mH	



Trim up

Trim down

Trim resistor connections (dashed line shows internal resistor network)

Trim				
Vout(V)	R1(KΩ)	R2(KΩ)	R3(K)	Vref(V)
5	2.4	2.344	13.62	2.5
12	8.2	2.153	17.34	2.5
15	12	2.388	21.01	2.5
24	10	1.158	10.71	2.5

$$\text{Up: } R_t = \frac{nR_2}{R_2 - n} - R_3 \quad n = \frac{V_{ref}}{V_o - V_{ref}} * R_1$$

$$\text{Down: } R_t = \frac{nR_1}{R_1 - n} - R_3 \quad n = \frac{V_o - V_{ref}}{V_{ref}} * R_2$$

All DC-DC converters of this series are tested before delivery using the recommended circuit shown in Fig. 2. Input and/or output ripple can be further reduced by appropriately increasing the input & output capacitor values Cin and Cout and/or by selecting capacitors with a low ESR (equivalent series resistance). Also make sure that the capacitance is not exceeding the specified max. capacitive load value of the product.

Dimensions and Recommended Layout

Dimensions

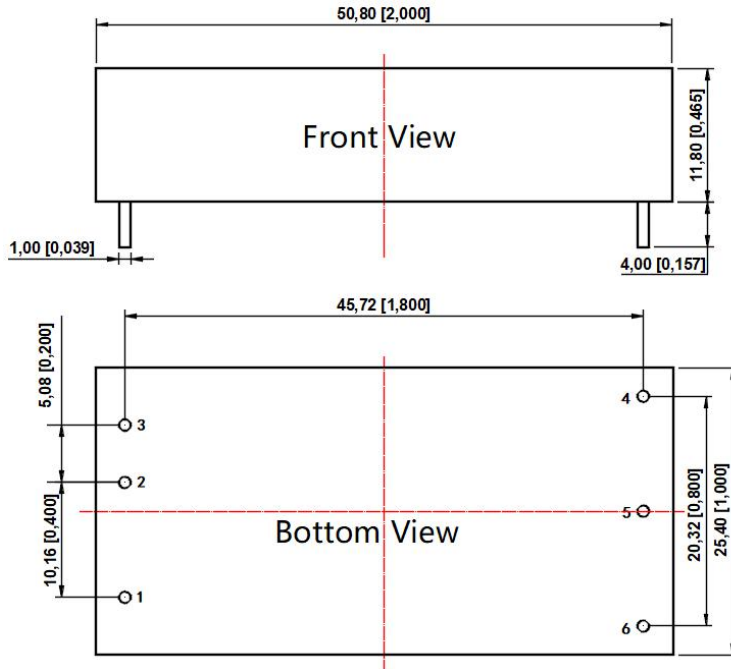

Note:
 Unit: mm[inch]
 Pin section tolerances: $\pm 0.10[\pm 0.004]$
 General tolerances: $\pm 0.50[\pm 0.020]$

PCB Printing Layout & Pin Definition Table

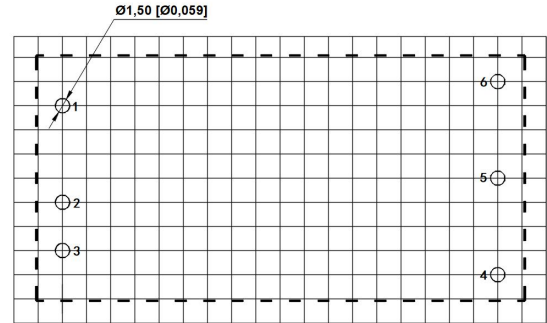

Note: The grid distance is 2.54*2.54mm

Pin	Function (Single)	Function (Dual)
1	GND	Vin
2	Vin	GND
3	+Vo	CTRL
4	Trim	-Vo
5	-Vo	COM
6	Ctrl	+Vo

Note:

1. If the product works under the minimum required load, it cannot guarantee that the performance of the product complies with all the performance indicators in this manual;
2. The maximum capacitive load is tested under the input voltage range and full load condition;
3. Unless otherwise stated, all indexes in this manual are measured at $T_a=25^\circ\text{C}$, humidity <75%RH, nominal input voltage and rated output load;
4. All index testing methods in this manual are based on the enterprise standards of the company;
5. Our company can provide product customization, specific needs can directly contact our technical staff;