

Product Feature

1. Package Type: 2"X 1"
2. Input voltage range: 4:1
3. Operating temperature range: -40°C - +85°C
4. Isolation voltage: 1500VDC
5. High efficiency up: 90% (Typ.)
6. Equipped with output short-circuit protection, overcurrent protection, and overvoltage protection mechanisms.
7. Fields of application: Industry, Power, Instrumentation, Communication, Rail transit.



3 years Warranty

Selection Guide

Part No.	Input Voltage (VDC)		Output		Full Load Efficiency% (Typ.)	Capacitive Load(μF) Max.
	Nominal (Range)	Max.	Voltage (VDC)	Current (mA)		
ATB2403LD-20WR3	24 (9-36)	40	3.3	5000/0	86	10000
ATB2405LD-20WR3		40	5	4000/0	88	10000
ATB2409LD-20WR3		40	9	2222/0	89	4700
ATB2412LD-20WR3		40	12	1667/0	89	1600
ATB2415LD-20WR3		40	15	1333/0	90	1000
ATB2424LD-20WR3		40	24	834/0	90	500
ATA2405LD-20WR3		40	±5	±2000/0	86	#4800
ATA2409LD-20WR3		40	±9	±1111/0	88	#1000
ATA2412LD-20WR3		40	±12	±834/0	88	#800
ATA2415LD-20WR3		40	±15	±667/0	88	#625
ATB4803LD-20WR3		48 (18-75)	80	3.3	5000/0	86
ATB4805LD-20WR3	80		5	4000/0	86	10000
ATB4809LD-20WR3	80		9	2222/0	89	4700
ATB4812LD-20WR3	80		12	1667/0	87	1600
ATB4815LD-20WR3	80		15	1333/0	90	1000
ATB4824LD-20WR3	80		24	834/0	88	500
ATA4805LD-20WR3	80		±5	±2000/0	86	#4800
ATA4812LD-20WR3	80		±12	±834/0	88	#800
ATA4815LD-20WR3	80		±15	±667/0	89	#625

#each output

Input Specifications

Item	Operating Conditions		Min.	Typ.	Max.	Unit
Input Current (full load/no-load)	24VDC nominal input series	3.3VDC Output	--	779/40	818/45	mA
		5VDC Output	--	969/40	993/80	
		Other Output	--	947/6	969/10	
	48VDC nominal input series	3.3VDC Output	--	400/20	409/25	
		5VDC Output	--	485/20	497/60	
		Other Output	--	474/5	485/9	

Reflected Ripple Current	24VDC nominal input series	--	30	--	mA
	48VDC nominal input series	--	30	--	
Impulse Voltage	24VDC nominal input series	-0.7	--	50	VDC
	48VDC nominal input series	-0.7	--	100	
Starting Voltage	24VDC nominal input series	--	--	9	
	48VDC nominal input series	--	--	18	
Input undervoltage protection	24VDC nominal input series	5.5	6.5	--	
	48VDC nominal input series	12	15.5	--	
Start time	Nominal input and constant resistance load	--	10	--	ms
Ctrl	Turn off module	connected GND or (0-1.2V)			
	Turn on module	No connected or (3.5-12V)			
	Input current when off	--	5	8	mA
Input Filter	PI filter				

Output Specifications

Item	Operating Conditions		Min.	Typ.	Max.	Unit
Output Voltage Accuracy	0%-100% load		--	±1	±3	%
Linear Regulation	Vin=Min. to Max. @Full Load	Positive output	--	±0.2	±0.5	
		Negative output	--	±0.5	±1	
Load Regulation	5%-100% load	Positive output	--	±0.5	±1	
		Negative output	--	±0.5	±1.5	
Cross adjustment rate	Dual output, main 50% load, secondary 10% -100%		--	--	±5	
Ripple & Noise	20MHz bandwidth,5%-100% load		--	50	100	mVp-p
Transient Recovery Time	25% Load Step Change, nominal input voltage		--	300	500	ms
Transient Response Deviation	25% Load Step Change, nominal input voltage	3.3V、5V、±5V output	--	±5	±8	%
		Other	--	±3	±5	
Temperature Coefficient			--	--	±0.03	%/°C
Trim	input voltage range		--	±10	--	%Vo
Over Voltage Protection	input voltage range		110	--	160	%Vo
Over Current Protection	input voltage range		110	--	--	%Io
Short-Circuit Protection	input voltage range		Continuous, Self-Recovery			

General Specifications

Item	Operating Conditions		Min.	Typ.	Max.	Unit
Isolation Voltage	Input-output, test time 1 minute, leakage current less than 1mA		1500	--	--	VDC
Insulation Resistance	Input-output, insulated voltage 500VDC		1000	--	--	MΩ
Isolation Capacitance	Input-output, 100KHz/0.1V	ATB2424LD-20WR3	--	2050	--	pF
		Other	--	1050	--	
Operating Temperature	See Fig 1、 Fig 2		-40	--	+85	°C
Storage Temperature			-55	--	+125	°C
Storage Humidity	Non-condensing		5	--	95	%RH

Soldering Profile	1.5mm from case for 10 sec	--	--	300	°C
Switching Frequency	PWM	--	270	--	kHz
MTBF	MIL-HDBK-217F@25°C	1000	--	--	K Hours

Mechanical Specifications

Case Material	Aluminum alloy
Package Dimensions	50.80 x 25.40 x 12.00mm
Weight	25.00g(Typ.)
Cooling Method	Free air convection

EMC Specifications

EMI	CE	CISPR32/EN55032 CLASS A(without external components)/CLASS B (see Fig. 3-②for recommended circuit)			
	RE	CISPR32/EN55032 CLASS A(without external components)/CLASS B (see Fig. 3-②for recommended circuit)			
EMS	ESD	IEC/EN61000-4-2 Contact±4KV	perf.	Criteria	B
	RS	IEC/EN61000-4-3 10V/m	perf.	Criteria	A
	EFT	IEC/EN61000-4-4 ±2KV (see Fig.3-① for recommended circuit)	perf.	Criteria	B
	Surge	IEC/EN61000-4-5 line to line±2KV(see Fig. 3-① for recommended circuit)	perf.	Criteria	B
	CS	IEC/EN61000-4-6 3 Vr.m.s	perf.	Criteria	A
	Voltage sag, drop, short-term interruption immunity	IEC/EN61000-4-29 0%, 70%	perf.	Criteria	B

Typical Characteristic Curves

Temperature Derating Curve (24V) Figure1

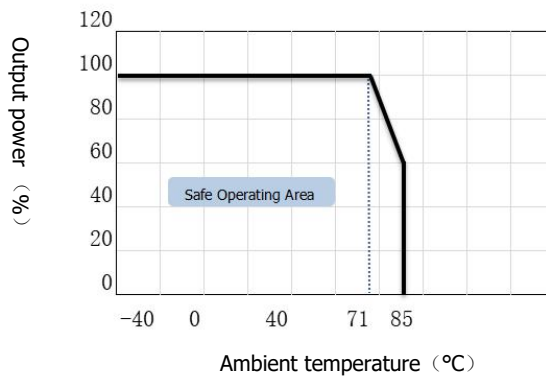

Efficiency Vs Input Voltage (Full Load)

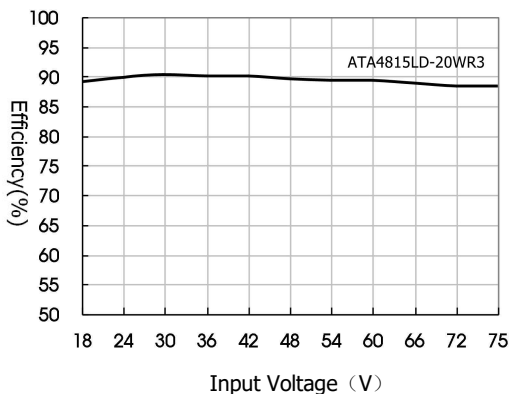

Efficiency Vs Output Load (Vin=24V)

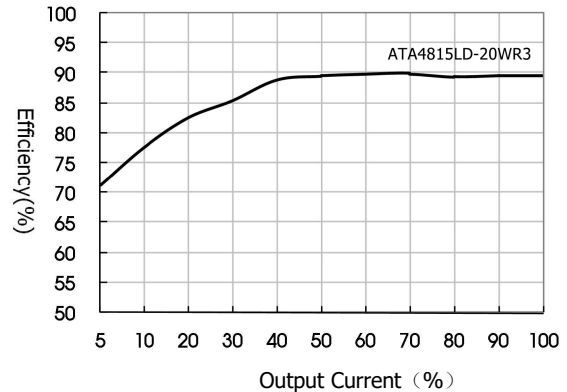

Efficiency Vs Input Voltage (Full Load)

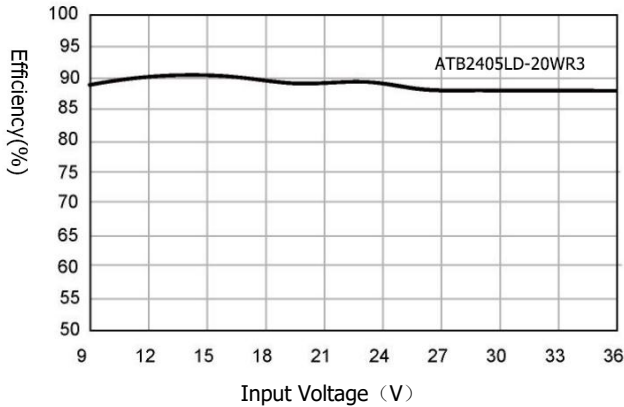

Efficiency Vs Output Load (Vin=24V)

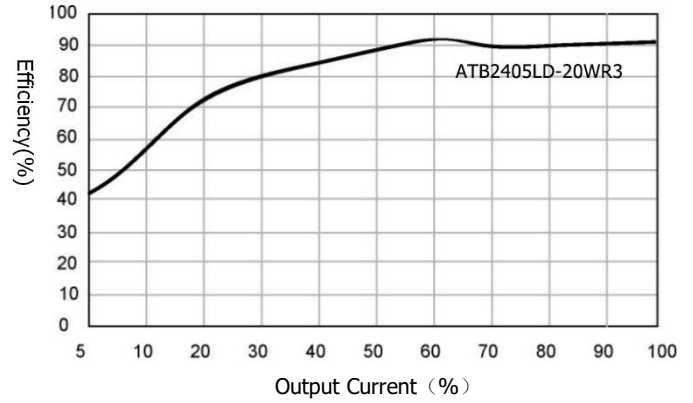

Typical Circuit Design And Application

Figure2

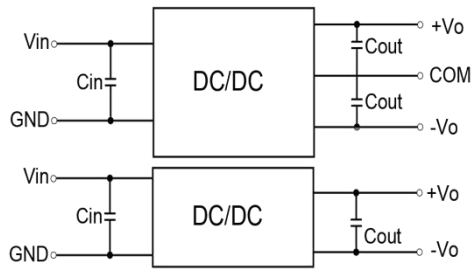

Recommended component parameters

Single output (VDC)	Cout (μF)	Cin (μF)	Dual output (VDC)	Cout (μF)	Cin (μF)
3.3/5	470	100	±5	220	100
9/12/15	220	100	±9/±12 ±15	100	100
24	100	100	--	--	100

Figure 3

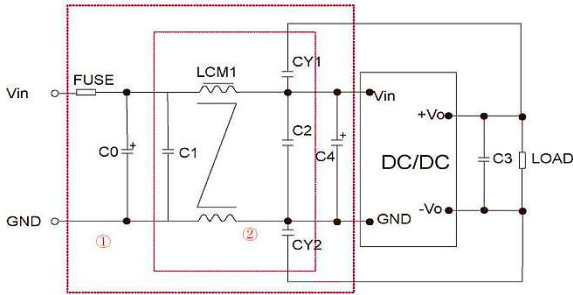

EMI Recommended component parameters

Vin(VDC)	24VDC	48VDC
FUSE	Choose according to actual input current	
C0、C3	330μF/50V	330μF/100V
C1	1μF/50V	1μF/100V
C2	Refer to the Cout in Fig.3	
LDM1	4.7μH/3.1A	
CY1、CY2	1nF/2KV	

Figure 4

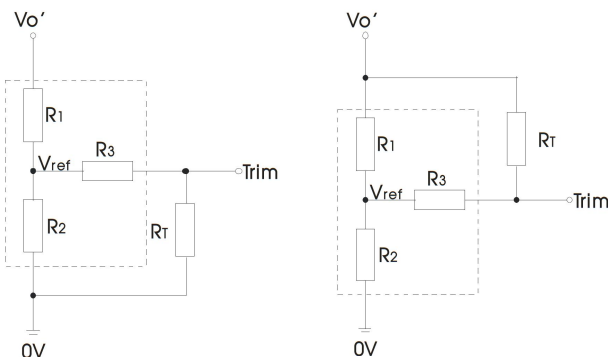

Trim Recommended component parameters

Vout	R1(KΩ)	R2(KΩ)	R3(KΩ)	Vref(V)
3.3	4.801	2.87	12.4	1.24
5	2.883	2.87	10	2.5
9	7.500	2.87	15	2.5
12	11.000	2.87	15	2.5
15	14.949	2.87	15	2.5

$$\text{Up: } R_t = \frac{nR_2}{R_2 - n} - R_3 \quad n = \frac{V_{ref}}{V_o - V_{ref}} * R_1$$

$$\text{Down: } R_t = \frac{nR_1}{R_1 - n} - R_3 \quad n = \frac{V_o - V_{ref}}{V_{ref}} * R_2$$

Trim up
Trim down
Trim resistor connections
(dashed line shows internal resistor network)

Note:

1. All DC-DC converters of this series are tested before delivery using the recommended circuit shown in Fig. 3.
2. Input and/or output ripple can be further reduced by appropriately increasing the input & output capacitor values C_{in} and C_{out} and/or by selecting capacitors with a low ESR (equivalent series resistance). Also make sure that the capacitance is not exceeding the specified max. capacitive load value of the product.
3. The products do not support parallel connection of their output.

Dimensions and Recommended Layout

Dimensions

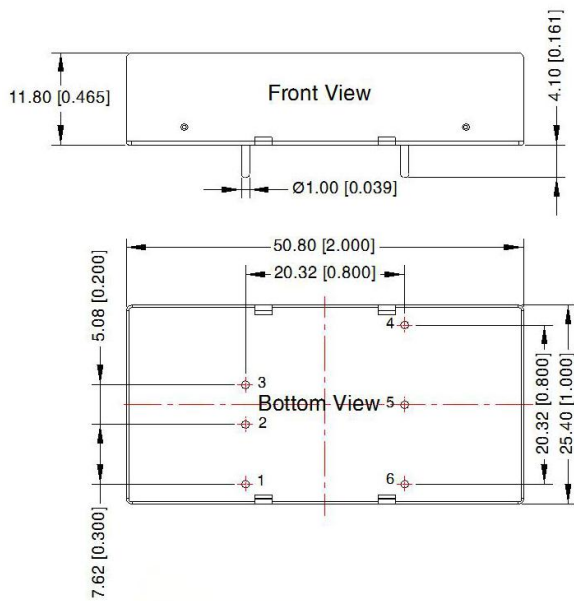

PCB Printing Layout

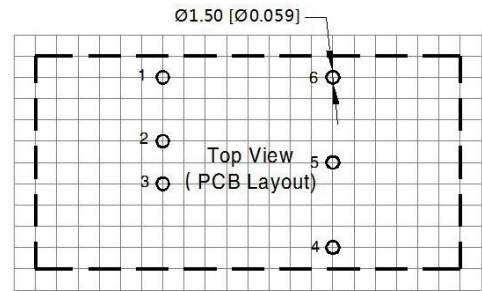

The grid distance is 2.54 x 2.54mm

Pin-Out

Pin	Single	Dual
1	CTRL	CTRL
2	GND	GND
3	Vin	Vin
4	+Vo	+Vo
5	Trim	Trim
6	-Vo	-Vo

Note:

Unit: mm[inch]

Pin section tolerances: ± 0.10 [± 0.004]

General tolerances: ± 0.50 [± 0.020]

Horizontal Package (with heat sink) Dimensions

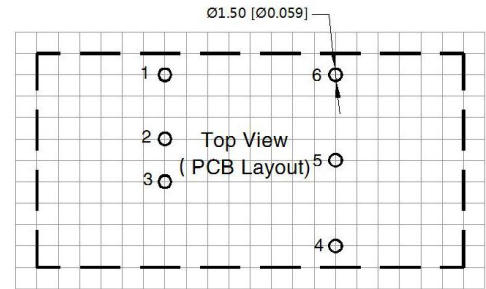
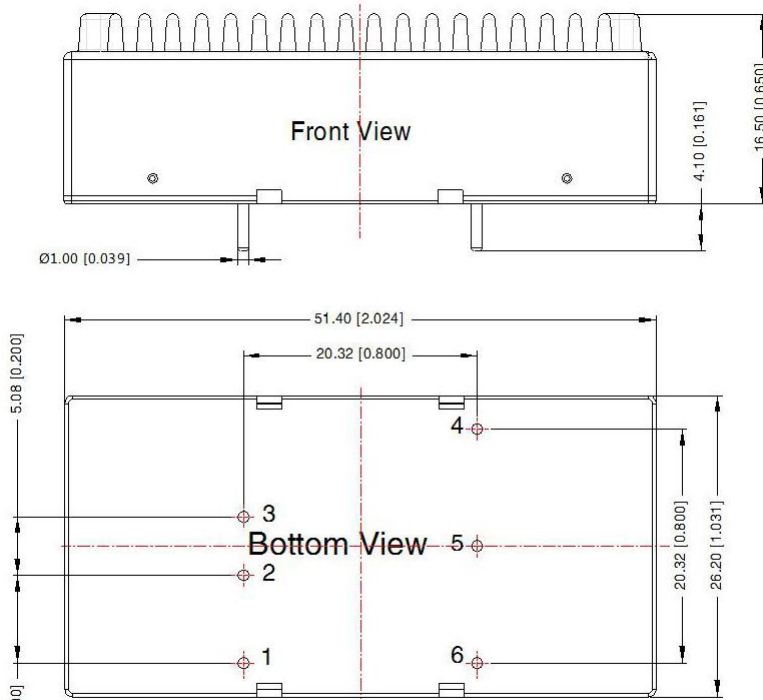

Note: Gird 2.54*2.54mm

Pin-Out		
Pin	Single	Dual
1	CTRL	CTRL
2	GND	GND
3	Vin	Vin
4	+Vo	+Vo
5	Trim	0V
6	0V	-Vo

Note:
Unit: mm[inch]
Pin section tolerances: ± 0.10 [± 0.004]
General tolerances: ± 0.25 [± 0.010]

ATA_LD-20WR3A2S & ATB_LD-20WR3A2S (without heat sink) Dimensions

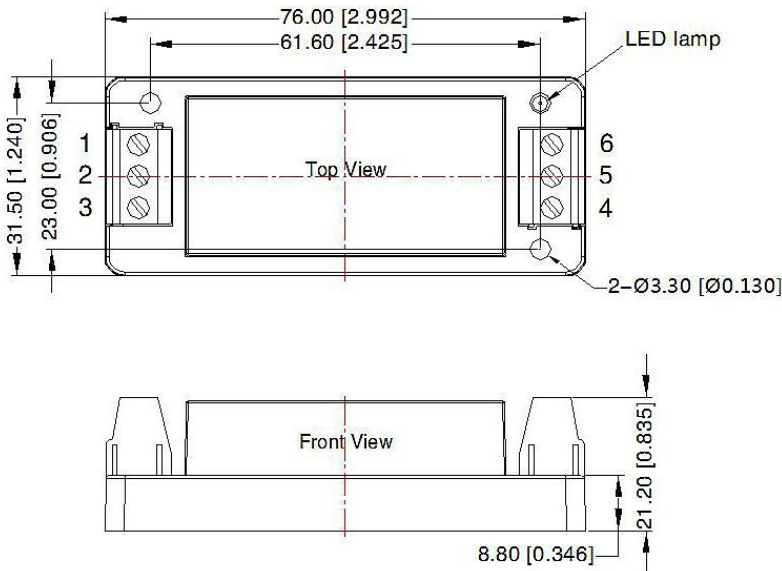

Pin-Out						
Pin	1	2	3	4	5	6
Single	Ctrl	GND	Vin	+Vo	Trim	0V
Dual	Ctrl	GND	Vin	+Vo	0V	-Vo

Note:
Unit: mm[inch]
Wire range: 24-12 AWG
Tightening torque: Max 0.4 N•m
General tolerances: ± 1.0 [± 0.039]

ATA_LD-20WHR3A2S & ATB_LD-20WHR3A2S(with heat sink) Dimensions

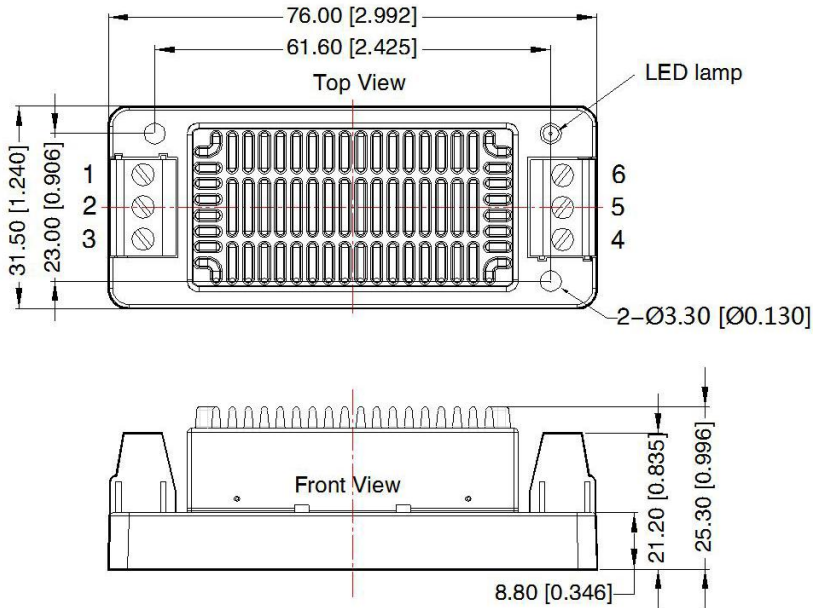

Pin	Pin-Out					
	1	2	3	4	5	6
Single	Ctrl	GND	Vin	+Vo	Trim	0V
Dual	Ctrl	GND	Vin	+Vo	0V	-Vo

Note:
 Unit: mm[inch]
 Wire range: 24-12 AWG
 Tightening torque: Max 0.4 N•m
 General tolerances: ±1.0[±0.039]

ATA_LD-20WR3A4S & ATB_LD-20WR3A4S(without heat sink) Dimensions

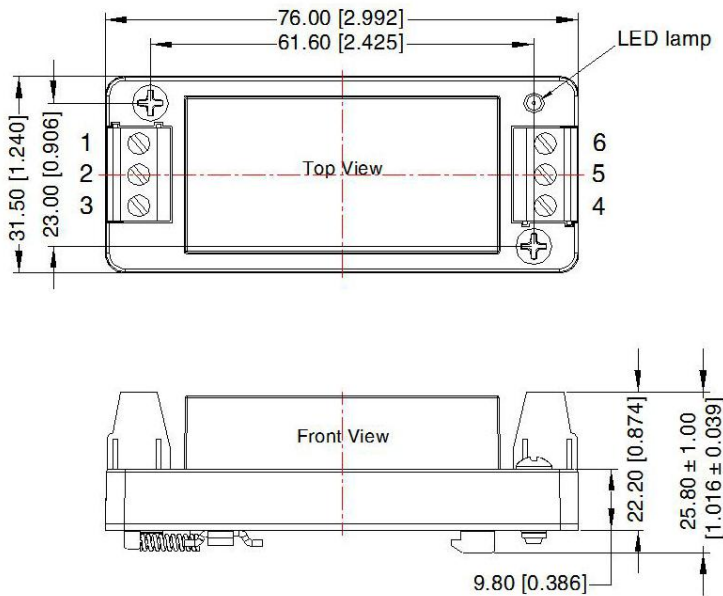

Pin	Pin-Out					
	1	2	3	4	5	6
Single	Ctrl	GND	Vin	+Vo	Trim	0V
Dual	Ctrl	GND	Vin	+Vo	0V	-Vo

Note:
 Unit: mm[inch]
 Mounting rail: TS35
 Wire range: 24-12 AWG
 Tightening torque: Max 0.4 N•m
 General tolerances: ±1.0[±0.039]

ATA_LD-20WHR3A4S & ATB_LD-20WHR3A4S(with heat sink) Dimensions

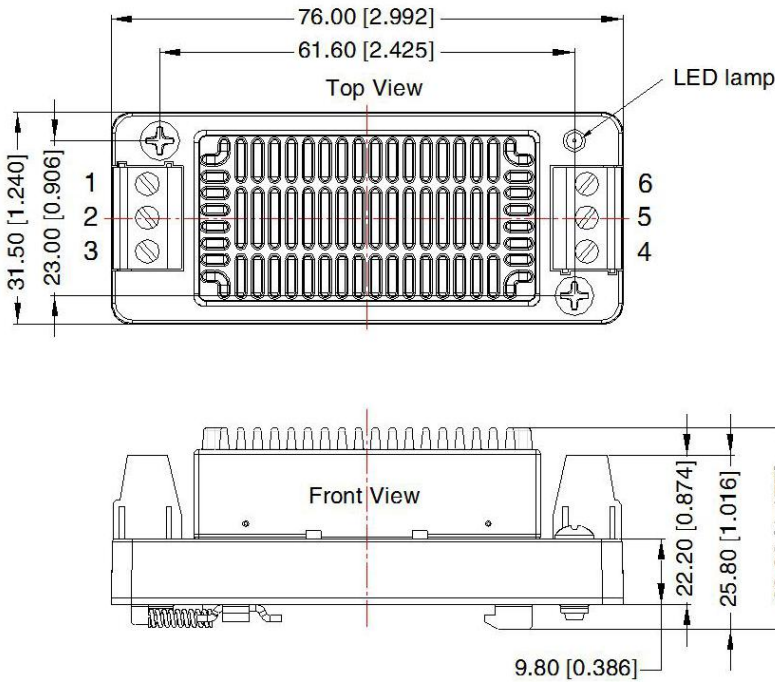

Pin	Pin-Out					
	Single	1	2	3	4	5
Dual	Ctrl	GND	Vin	+Vo	Trim	0V
	Ctrl	GND	Vin	+Vo	0V	-Vo

Note:
 Unit: mm[inch]
 Mounting rail: TS35
 Wire range: 24-12 AWG
 Tightening torque: Max 0.4 N*m
 General tolerances: ±1.0[±0.039]

Note:

1. The input voltage should not exceed the specified range value, otherwise it may cause permanent and irreparable damage;
2. It is recommended to use at a load of over 5%. If the load is below 5%, the ripple index of the product may exceed the specifications, but it does not affect the reliability of the product;
3. Suggested dual output module load imbalance: $\leq \pm 5\%$. If it exceeds $\pm 5\%$, it cannot be guaranteed that the product performance meets all performance indicators in this manual;
4. The maximum capacitive load is tested within the input voltage range and under full load conditions;
5. Unless otherwise specified, all indicators in this manual are measured at $T_a=25\text{ }^\circ\text{C}$, humidity < 75% RH, nominal input voltage, and output rated load;
6. All indicator testing methods in this manual are based on our company's corporate standards;
7. Our company can provide product customization, and specific requirements can be directly contacted by our technical personnel;
8. Product specifications are subject to change without prior notice.