

Product Feature

1. Package Type: 2"X 1"
2. Operating temperature range: -40°C - +105°C
3. Isolation voltage: 1500VDC
4. High efficiency up to 93%
5. The mechanism has input undervoltage protection, output short circuit protection and over current protection
6. 4:1 Ultra-wide input voltage range
7. Fields of application: Power, industrial control, communications, Internet of Things, automotive, etc



3 years
Warranty

Selection Guide

Part No.	Input Voltage (VDC)		Output			Capacitive Load(μF) Max.
	Nominal (Range)	Maximum	Voltage (VDC)	Current Min.(mA)	Current Max.(mA)	
ATB2405LD-40WR3	24 (9-36)	40	5	8000/0	89/91	15000
ATB2409LD-40WR3			9	4444/0	89/91	4700
ATB2412LD-40WR3			12	3333/0	90/92	3000
ATB2415LD-40WR3			15	2666/0	91/93	2200
ATB2424LD-40WR3			24	1666/0	90/92	1300
ATB4805LD-40WR3	48 (18-75)	80	5	8000/0	89/91	15000
ATB4812LD-40WR3			12	3333/0	90/92	3000
ATB4815LD-40WR3			15	2666/0	91/93	2200
ATB4824LD-40WR3			24	1666/0	90/92	1300

Input Specifications

Item	Operating Conditions		Min.	Typ.	Max.	Unit
Input Current(full load/no-load)	24VDCnominal input series	5VDC	--	1894/60	1938/100	mA
		Other	--	1852/12	1894/25	
	48VDCnominal input series		--	926/12	947/25	
Reflected Ripple Current			--	--	40	
Impulse Voltage	24VDCnominal input series		-0.7	--	50	VDC
	48VDCnominal input series		-0.7	--	100	
Starting Voltage	24VDCnominal input series		--	--	9	
	48VDCnominal input series		--	--	18	
Input undervoltage protection	24VDCnominal input series		5.5	6.5	--	
	48VDCnominal input series		12.0	15.5	--	
Ctrl	turn off module		connected GND or (0-1.2V)			
	turn on module		No connected or (3.5-12V)			
	Input current when off		--	5	10	mA
Input Filter			PI filter			

Output Specifications

Item	Operating Conditions		Min.	Typ.	Max.	Unit
Output Voltage Accuracy	5%-100% load		--	±1.0	±3.0	%
Linear Regulation	Vin=Min. to Max. @Full Load		--	±0.2	±0.5	
Load Regulation	5%-100% load		--	±0.5	±1.0	
Transient Recovery Time	25% Load Step Change,nominal input voltage		--	250	500	µs
Transient Response Deviation	25% step change , nominal input	5VDC	--	±5	±8	%
Ripple & Noise	20MHz bandwidth,5%-100% load		--	100	200	mVp-p
	20MHz bandwidth,0%-100% load	5VDC	--	--	5	%Vo
		Other	--	--	3	
Over Voltage Protection			110	160	160	%Vo
Over Current Protection	input voltage range		110	140	--	%Io
Short-Circuit Protection			Continuous, Self-Recovery			

General Specifications

Item	Operating Conditions	Min.	Typ.	Max.	Unit
Isolation Voltage	Input-output, test time 1 minute, leakage current less than 1mA	1500	--	--	VDC
Insulation Resistance	Input-output, insulated voltage 500VDC	1000	--	--	MΩ
Isolation Capacitance	Input-output, 100KHz/0.1V	--	2000	--	pF
Operating Temperature	See Figure 1	-40	--	105	°C
Storage Temperature		-55	--	125	
Storage Humidity	Non-condensing	5	--	95	%RH
Soldering Profile	1.5mm from case for 10 sec	--	--	300	°C
Switching Frequency	Full load, nominal input voltage	--	330	--	kHz
MTBF	MIL-HDBK-217F@25°C	>1000Kh			

Mechanical Specifications

Case Material	Aluminum alloy
Package Dimensions	50.80mm * 25.40mm * 11.80 mm
Weight	41.0g
Cooling Method	Free air convection

EMC Specifications

EMI	CE	CISPR32/EN55032	CLASS A/CLASS B
	RE		
EMS	ESD	EN61000-4-2 Air ± 8kV , Contact ± 6kV	perf. Criteria B
	RS	EN61000-4-3 10V/m	perf. Criteria A
	EFT	EN61000-4-4 ±2kV	perf. Criteria A
	Surge	EN61000-4-5 ±2kV	perf. Criteria A
	CS	EN61000-4-6 10Vrms	perf. Criteria A

Typical Characteristic Curves

Temperature Derating Curve (24V)

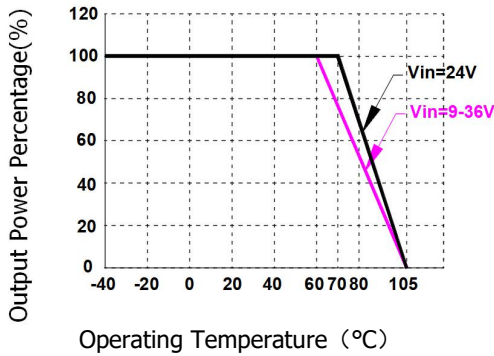

Fig 1

Temperature Derating Curve (48V)

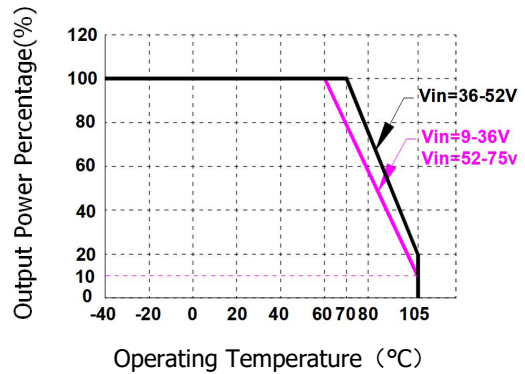
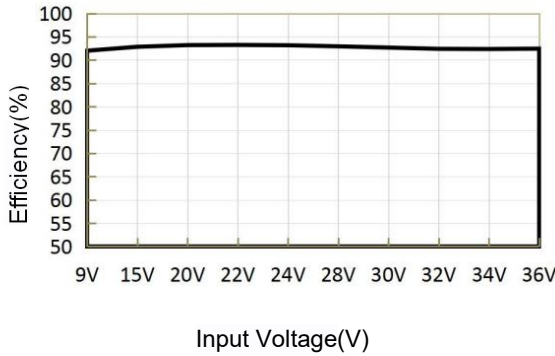
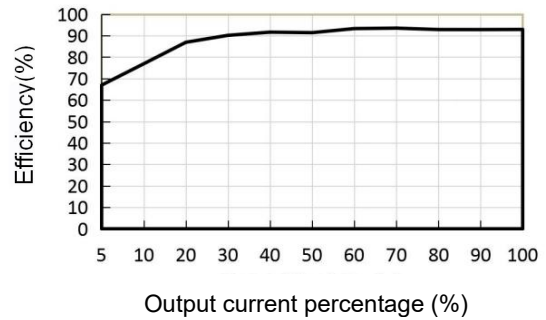

Fig 2

Efficiency VS input voltage (full load)



Efficiency VS out load (Vin=24)



Typical Circuit Design And Application

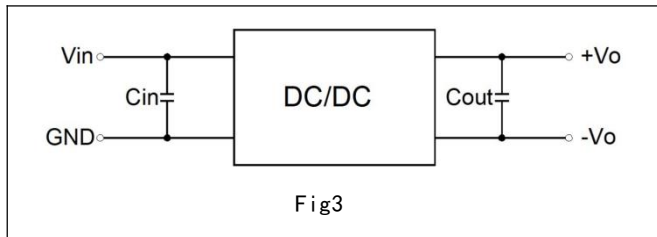

Fig 3

recommended component parameters		
Vo(VDC)	Cin(uF)	Cout(uF)
5/12/15	100	100
24		47

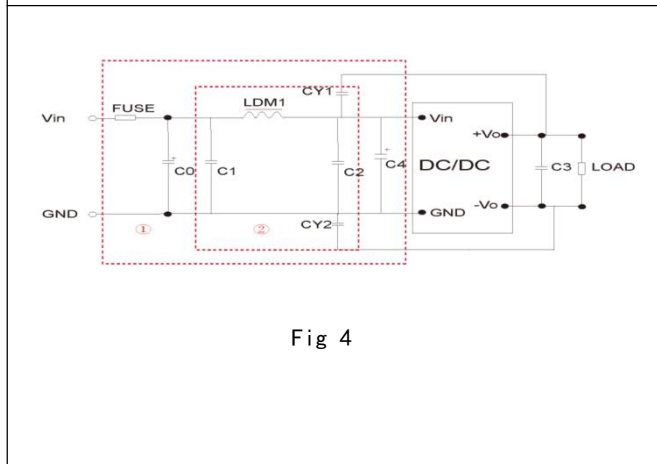
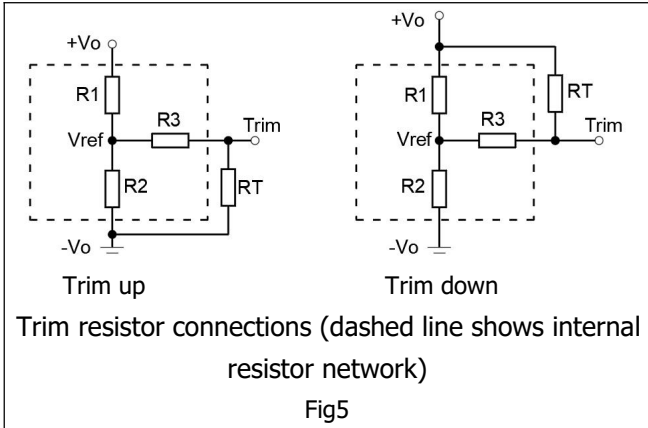

Fig 4

EMI recommended component parameters		
Model	Vin:24V	Vin:48V
FUSE	Select according to the actual input current of the customer	
C0、C4	330μF/50V	330μF/100V
C1、C2	4.7μF/50V	4.7μF/100V
C3	Refer to the Cout parameter in Figure 5	
LCM1	2.2uH/4A	2.2uH/2A
CY1/CY2	1nF/2KV	



Trim				
Vout(V)	R1(KΩ)	R2(KΩ)	R3(KΩ)	Vref(V)
5	2.4	2.344	13.622	2.5
12	8.2	2.153	17.346	2.5
15	12	2.388	21.016	2.5
24	10	1.158	10.714	2.5
$Up: R_t = \frac{nR_2}{R_2 - n} - R_3 \quad n = \frac{V_{ref}}{V_o - V_{ref}} * R_1$ $Down: R_t = \frac{nR_1}{R_1 - n} - R_3 \quad n = \frac{V_o - V_{ref}}{V_{ref}} * R_2$				

Dimensions and Recommended Layout

Dimensions PCB Printing Layout & Pin Definition Table

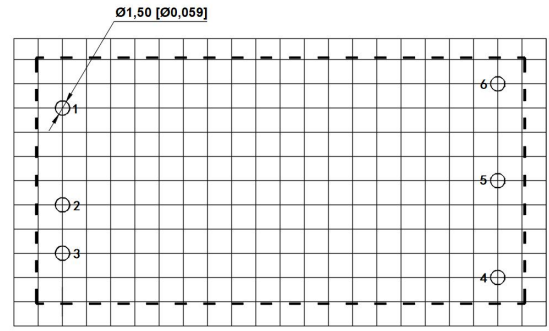
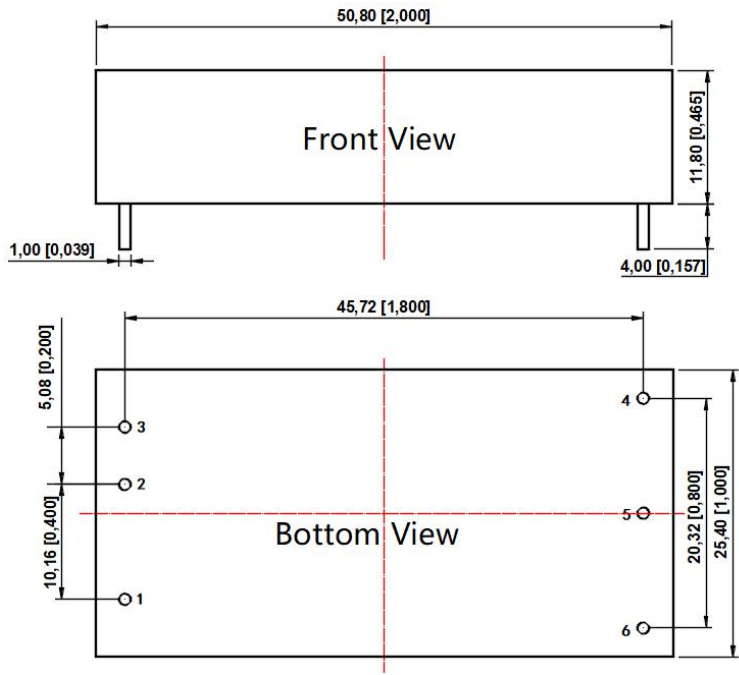

Note: The grid distance is 2.54*2.54mm

Pin	Function (Single)
1	Ctrl
2	GND
3	Vin
4	+Vo
5	-Vo
6	Trim

Note:
 Unit: mm[inch]
 Pin section tolerances: ±0.10[±0.004]
 General tolerances: ±0.50[±0.020]

Note:

1. If the product works under the minimum required load, it cannot guarantee that the performance of the product complies with all the performance indicators in this manual;
2. The maximum capacitive load is tested under the input voltage range and full load condition;
3. Unless otherwise stated, all indexes in this manual are measured at $T_a=25^{\circ}\text{C}$, humidity $<75\%RH$, nominal input voltage and rated output load;
4. All index testing methods in this manual are based on the enterprise standards of the company;
5. Our company can provide product customization, specific needs can directly contact our technical staff;

GUANGZHOU AMCHARD-POWER TECHNOLOGY CO., LTD.

www.amchard-power.com

Mail:info@amchard-power.com